

Design and Implementation of Single Phase Inverter Based on Cuk Converter for PV System

Jayalakshmi N. S. *[‡], D. N. Gaonkar***, Anandh N. * and Nimika Sanjeev Kumar*

*Department of Electrical and Electronics Engineering, Manipal Institute of Technology, Manipal, India-576104

**Department of Electrical and Electronics Engineering, National Institute of Technology, Karnataka, Surathkal, India-575025

[‡] Corresponding Author; Jayalakshmi N. S., Department of Electrical and Electronics Engineering, Manipal Institute of Technology, Manipal, India-576104, Tel: +91-9481970925, jayalakshmi.ns@manipal.edu

Received: 25.10.2016 Accepted: 07.12.2016

Abstract - In this paper, analysis and hardware implementation of a single phase inverter based on Cuk converter for PV system is presented. The buck-boost characteristic of such a converter promotes flexibility for both grid tied as well as standalone connections where the ac voltage is either higher than or lesser than the dc input voltage. Further Cuk based topologies have the better efficiency and voltage regulation, which is a lacking feature in a basic boost or a buck configuration. The proposed system not only offers continuous input and output current but also controlled voltage over a wider range. Hence this topology can serve as an expedient alternative converter stage for photovoltaic applications. In the proposed bidirectional two-switch Cuk converter, DSPIC30F2010 controller is used for controlling the duty ratio of switching pulses. Also, this controller generates PWM signals for the switches of single phase H-bridge inverter. The hardware results for the developed prototype of a Cuk converter based single phase inverter are presented. The developed scheme can easily be scalable to a much larger rating of the PV system.

Keywords – Photovoltaic (PV) Systems, Maximum Power Point Tracking, Cuk converter, DSP controller, Single phase inverter.

1. Introduction

For conversion of dc power to ac, the most frequently used converter topology is the traditional voltage source inverter (VSI) [1]. Since, the instantaneous value of average output voltage of the VSI at any instant is consistently lesser than the dc source voltage, a dc-dc boost converter is recommended [2]. In [3], this configuration is employed to build a single power staged single-phase system for a fuel cell application with a battery as the backup unit for storage. The analysis and design with experimental results of a boost dc-ac converter in place of the conventional VSI is detailed in [1]. It is possible to use a higher order converter in place of the first order boost converter. Owing to the various advantages, [4] shows that among the nine possible continuous current converters, Cuk converter with two inductors and one capacitor is the best possible option. Hence Cuk converter can be chosen as the higher order converter for the implementation of the inverter. Further, another option is to replace the diode in the conventional Cuk converter with a switch [5].

The conventional two-stages of control for photovoltaic system primarily consists of dc-dc conversion, whose output

is a stiff dc voltage, which is actually a high frequency signal filtered using large electrolyte capacitors. The next step is dc-ac conversion which is switched using sinusoidal pulse-width modulation (PWM) controls to transfer the energy from the source to the receiving end utility. On the contrary, the controls based on only a single-stage for a PV system consists of only one dc-dc stage, with no electrolyte capacitors, giving a pulsating high-frequency output to an unfolding 60 Hz full-bridge inverter for the same energy transfer [6]. In general, such inverters which have only one stage are classified into the following different forms of systems: Buck-boosting type, H-Bridge Inverter, Z-Source Inverter and Fly-back type inverting Chopper. In [7], these inverter topologies are put into comparison on the basis of the examination of their performance traits such as efficiency, switching frequency, switching method, power output and power factor.

The output of the panel varies with the incident irradiance levels and the temperature, in other words any change in the weather has an effect on the power generated from PV panel. Hence, in order to maximize the produced solar energy, a method for tracking the Maximum Power Point or MPPT is used. A circuit design technique for such an application, that is to follow the maximum power point (MPP), on the panel

power versus voltage graph, is elaborately explained in [8]. Another such scheme, with lesser number of sensors suitable for a grid-tied single phase conversion is proposed in [9]. This is also a single-stage topology, operating in continuous current conduction mode commonly known as Continuous Conduction Mode (CCM). Finally, a study that compares seven frequently employed MPPT algorithms, comparing in particular, the behavioral changes of every technique when there are variations in solar irradiation is reported in [10].

In this paper, a single stage inverter based on a higher order Cuk converter with two switches instead of a simple boost converter is developed. Since the diode in a conventional Cuk converter acts like a switch conducting in off time period and open circuit in the on time period, it can be replaced by a convenient semiconductor switch; for example a MOSFET switch. Such a configuration can be extended to the converter with bidirectional property, allowing efficient three phase grid connected system. Also, it enables the consumer to supply to the grid when producing enough power from the PV arrays or to utilize the grid power when the weather limits the individual power generation.

2. System Description

The schematic diagram of the modified dc-dc Cuk converter is illustrated in Fig. 1. It comprises of an input source voltage (V_{in}), with inductors, L_1 and L_2 , with one coupling capacitor (C_1) as the energy storing elements. The energy is transferred via C_1 , with L_1 and L_2 being instantly energized. The steady state operation is described as follows; when S_1 is considered to be OFF in the first part of the switching period, capacitor C_1 is charged which leads to decrease the current I_{L1} . The energy is shifted from L_2 to the load causing current I_{L2} to increase (note that output is inverted with respect to the input polarity). In the next part of the switching period, when S_1 is On, L_1 is energized letting I_{L1} to increase, whereas C_1 is discharged causing I_{L2} to decrease. This shows that I_{L1} and I_{L2} are co-related by the transfer of energy through C_1 .

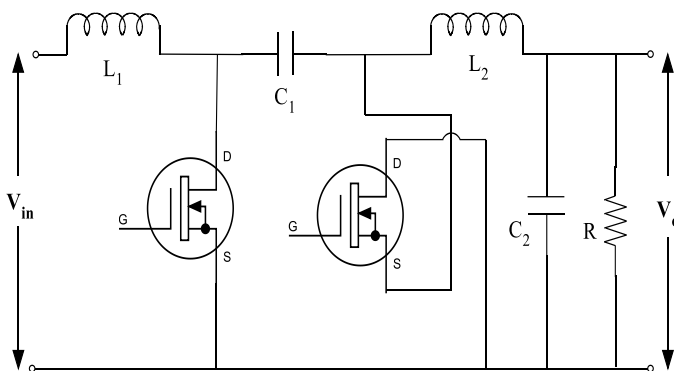

Fig. 1: Block diagram of Cuk converter

It is assumed that the time period for which S_1 is off is T_{OFF} , the time for which S_1 is on is T_{ON} and $T_s = T_{ON} + T_{OFF}$ and the complementary is for S_2 . The method of state space averaging is applied for modelling the Cuk converter [5]. Thereafter, for operation in CCM, the state space equations are as follows.

(i) When S_1 is OFF and S_2 is ON ($0 < t < T_{OFF}$):
 During this period, the state space equations are represented by

$$\dot{x}_1 = \begin{bmatrix} 0 & -1/L_1 & 0 \\ 1/C_1 & 0 & 0 \\ 0 & 0 & -R/L_2 \end{bmatrix} x_1 + \begin{bmatrix} 1/L_1 \\ 0 \\ 0 \end{bmatrix} V_{in} \quad (1)$$

$$v_{O1} = [0 \ 0 \ R] x_1 \quad (2)$$

Where $x_1 = \begin{bmatrix} i_{L1} \\ v_{C1} \\ i_{L2} \end{bmatrix}$

(ii) When S_1 is ON and S_2 is OFF ($T_{OFF} < t < T_s$):
 In this period of consideration, the state space equations are given by

$$\dot{x}_2 = \begin{bmatrix} 0 & 0 & 0 \\ 0 & 0 & -1/C_1 \\ 0 & 1/L_2 & -R/L_2 \end{bmatrix} x_2 + \begin{bmatrix} 1/L_1 \\ 0 \\ 0 \end{bmatrix} V_{in} \quad (3)$$

$$v_{O2} = [0 \ 0 \ R] x_2 \quad (4)$$

Where $x_2 = \begin{bmatrix} i_{L1} \\ v_{C1} \\ i_{L2} \end{bmatrix}$

On being averaged over one switching period [$0 < t < T_s$], the state space equations (1) to (4) yield the following equations. Here the duty ratio is assumed to be $d = T_{ON}/T_s$.

$$\dot{x} = \begin{bmatrix} 0 & -(1-d)/L_1 & 0 \\ (1-d)/C_1 & 0 & -d/C_1 \\ 0 & d/L_2 & -R/L_2 \end{bmatrix} x + \begin{bmatrix} 1/L_1 \\ 0 \\ 0 \end{bmatrix} V_{in} \quad (5)$$

$$v_O = [0 \ 0 \ R] x \quad (6)$$

Where $x = \begin{bmatrix} i_{L1} \\ v_{C1} \\ i_{L2} \end{bmatrix}$

From the above equation, $G_v (V_o/V_{in})$ which is the system transfer function or the voltage gain can be formulated as

$$G_v = \frac{Rd(1-d)}{C_1L_1L_2s^3 + C_1L_1Rs^2 + (L_2 - 2dL_2 + d^2L_2 + d^2L_1)s + (R - 2Rd + Rd^2)} \quad (7)$$

From the equation for G_v , it is seen that the output voltage dynamically varies with the duty ratio d . If duty ratio $d = \delta$ is considered to be constant then when $s \rightarrow 0$, the steady state transfer function becomes:

$$G_{v,ss} = \frac{\delta}{(1-\delta)} \quad (8)$$

3. Dynamic Analysis of the Converter

The simulations were carried out with the derived transfer function of the converter in equation 7. Since this transfer function G_v suggests that the output voltage is a function of the converter parameters and duty ratio, pole zero map and step response were considered to analyze the dynamic behavior of the system for different duty ratio. In Table I, the parameters of Cuk converter are given. The pole-zero map of G_v are plotted in Fig. 2(a). The duty ratio is varied from 0.1 to 0.80 in steps of 0.1. Inference drawn from the simulation is that when duty ratio increases, the real axis poles moves towards the slower region; in other words they are shifting nearer to the origin. This means that dynamically the system is becoming slower. This is also verified from Fig. 2(b) which depicts the step response showing that the system happens to become slower with increasing duty ratio.

TABLE I

Parameter	Value
L1	0.2mH
L2	0.2mH
C1 (coupling capacitor)	10uF
C2 (output filter capacitor)	5uF

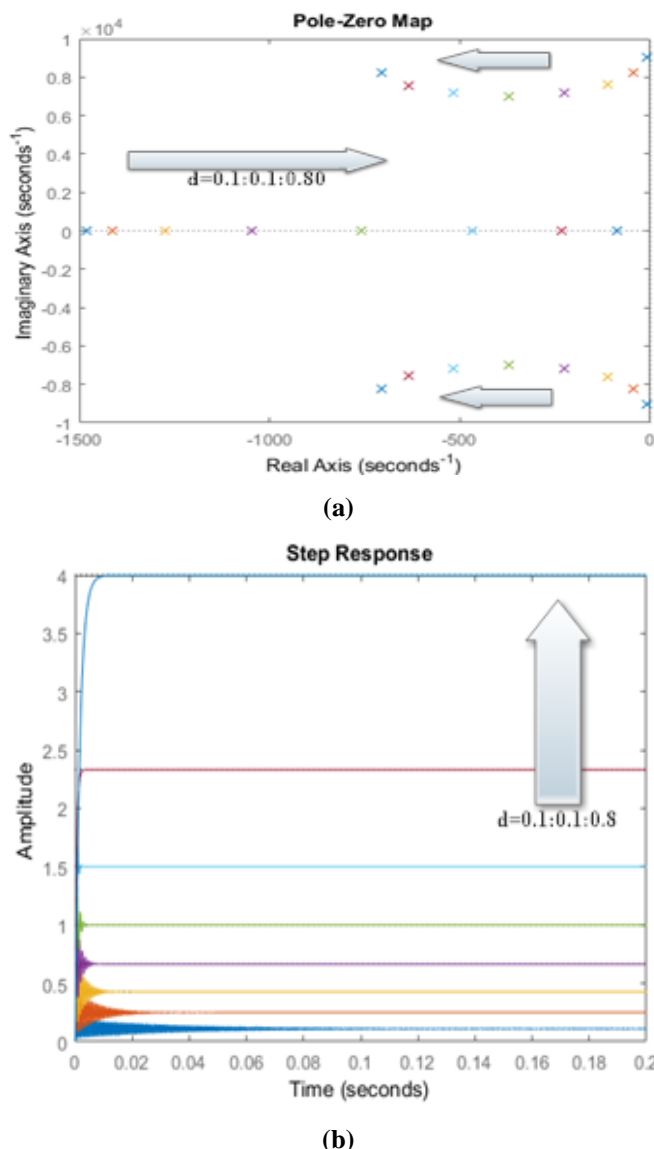

Fig. 2: Dynamic Response Analysis (a) Pole Zero map for G_v (b) Step Response of G_v

The above analysis was important to determine the range of duty ratios that will give the desired results for system. The PV array generates power which varies with the weather changes, temperature and irradiance levels, which in turn produces variable voltage. Whenever source voltage is from solar origin the circuits should be designed keeping this nonlinearity of voltage current or power voltage relationship. In order to overcome the imperfections in these power sources, the circuit should shift its point of dynamics over the feasible range of duty ratios. Since the root cause of these variations is the weather dependent internal resistance of the PV panel, the input impedance of the voltage converter should adapt in such a way, so as to match the value of this internal resistance. The maximum power is obtained if the pulse width of the switching control signal is measured and varied in such a way that the circuit resistance is equal to the internal resistance of the source.

4. MPPT Controller

As discussed earlier there is nonlinearity in the voltage-current characteristics of solar panels. In order to incessantly harvest maximum power from the photovoltaic panels, they should operate at their MPP despite the unavoidable changes in the environment conditions. This is the reason the solar panels employ some techniques for extracting maximum power from it. Over the past ten years a number of methods for MPPT have been illustrated [12-15]. Fig. 4 shows a schematic representation of the system with the enhancement of maximum power point tracking system. Perturb and Observe method is chosen for extracting maximum power from panels.

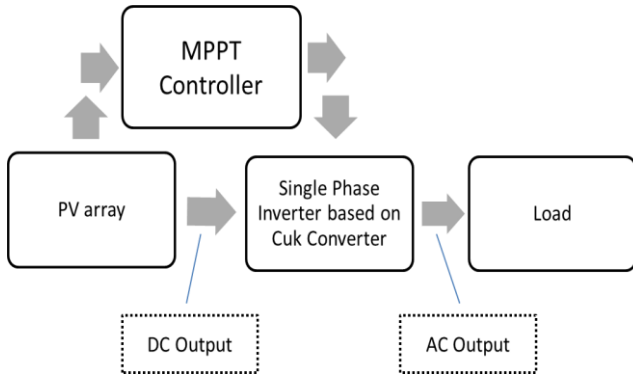

Fig. 4: Block Diagram with MPPT Control

Out of the many MPPT algorithms the P&O MPPT algorithm was chosen since it is widely used due to its ease of implementation. The flow chart for Perturb and Observe MPPT Algorithm is depicted in Fig.5. The P&O algorithm is fast, efficient and easy to implement [10]. It exploits the fact that MPP is at the peak of the P-V curve. In order to track rapidly increasing and decreasing irradiance conditions with higher accuracy, very small perturbations with small sampling time should be adopted. In this algorithm firstly, the instantaneous power $P(k)$ and voltage $V(k)$ of the PV array of the measured (where k is the iterating variable). Then operating voltage is varied or perturbed by a small value in a particular direction. If the circuit is observed to extract increased power from the photovoltaic source due to the above perturbation, then the operating point has traversed towards the point of maximum power. This implies that the voltage at the point of operation should be perturbed again keeping the sense of direction same. On the other hand, if the power extracted from the photovoltaic source had decreased, it would confirm that the operating point has traversed further far off from the MPP. Hence, there should be a reversal in the direction of the perturbation in the operating voltage.

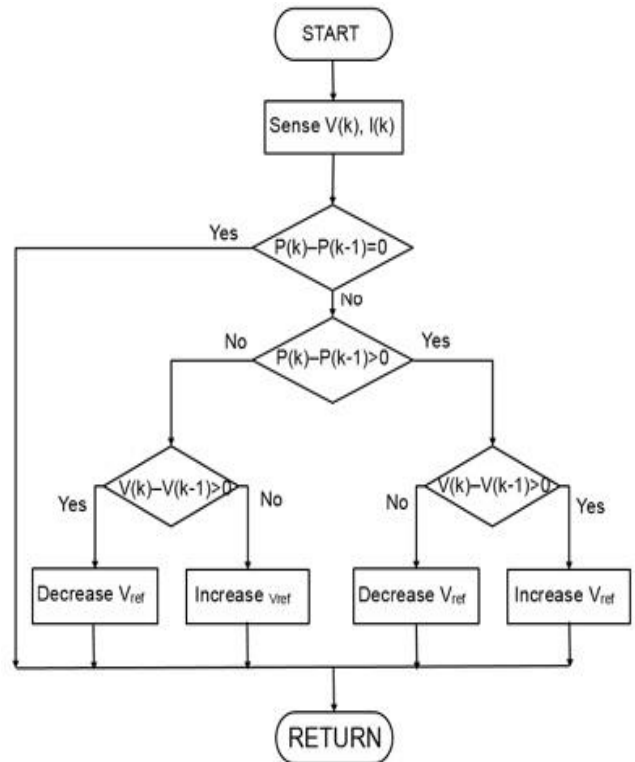
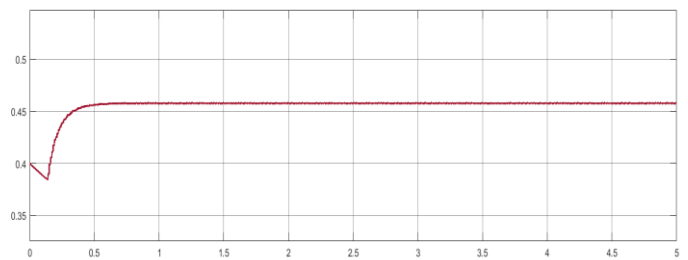

Fig. 5: Flow Chart for Perturb and Observe MPPT Algorithm

5. Simulation Results

The implemented single-phase Cuk based inverter is analyzed with the help of simulated results in MATLAB/Simulink platform. The PV panel is output rating is 10W and the input voltage of the Cuk converter is 15V. In order to verify buck-boost operation of Cuk converter, the simulation results are shown in Fig. 6 and Fig. 7. For duty ratio of 45.8% as shown in Fig. 6 (a), the converter output is observed to be 14V which is lesser than 15V. If the duty ratio is 50%, the output voltage is higher than input voltage of 15V. For duty ratio of 52.6% as shown in Fig. 7 (a), the converter output is 18.8V as depicted in Fig. 7 (b).



(a)

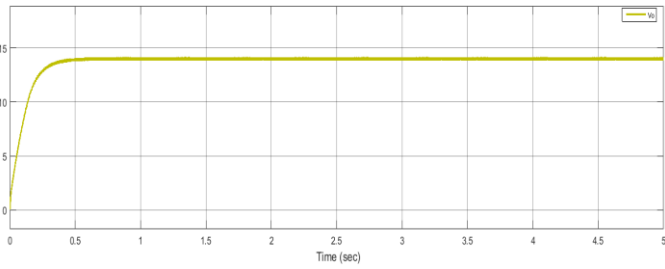

(b)

Fig. 6: (a) Duty ratio less than 50% (b) Converter Output Voltage

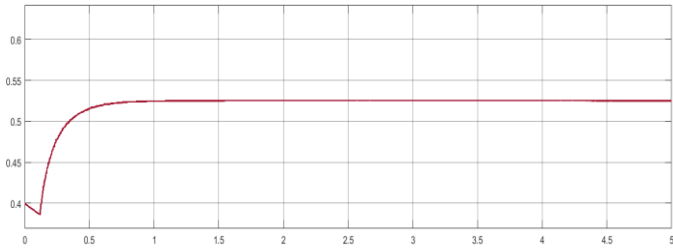

(a)

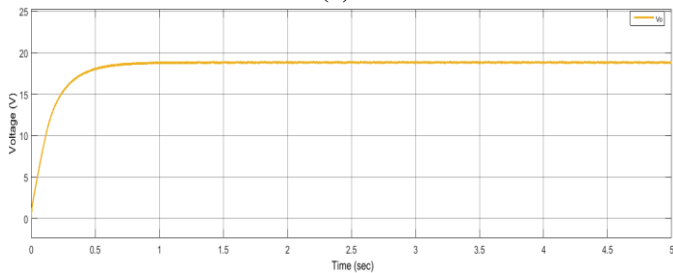

(b)

Fig. 7: (a) Duty ratio more than 50% (b) Converter Output Voltage

6. Experimental Results

The schematic block diagram of the developed Cuk converter based inverter with controller is depicted in Fig. 8. Fig.9 depicts the detailed configuration of driver circuits for generating PWM signals for Cuk converter and inverter with DSP controller. The hardware set up of the prototype is shown in Fig 10. The triggering signals which are used to control the switching of S_1 and S_2 of the Cuk converter are shown in Fig. 11.

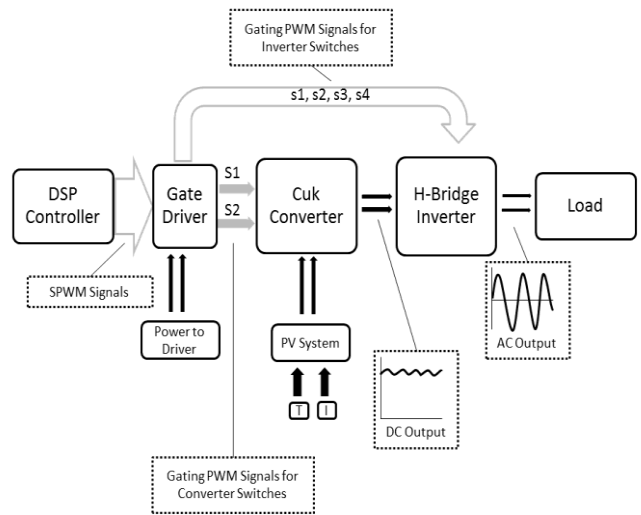

Fig. 8: Block diagram of the system

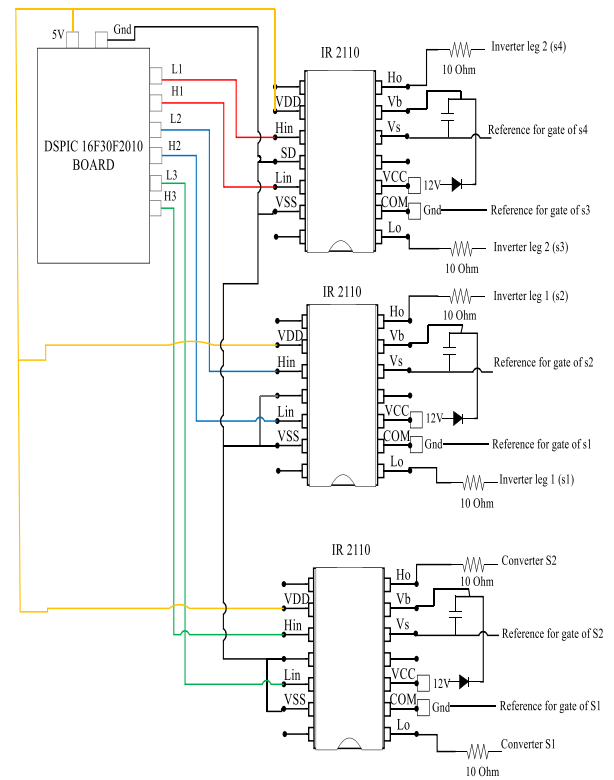

Fig.9: Detailed driver circuitry with DSP controller



Fig. 10: Prototype model of Cuk converter based inverter

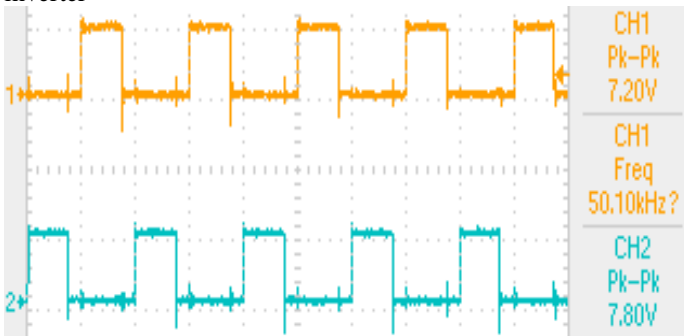
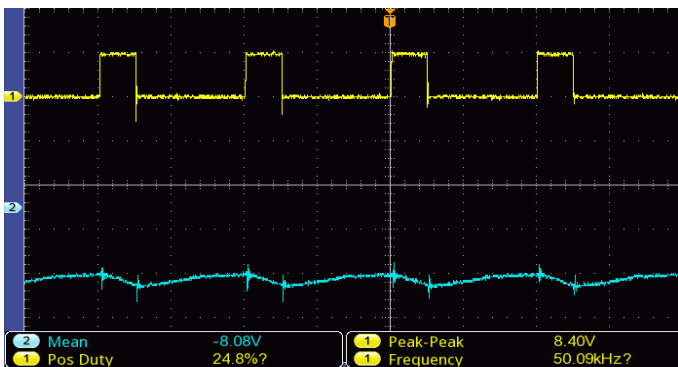
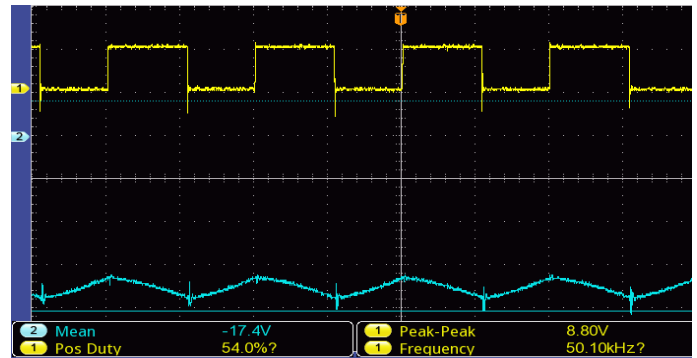

Fig. 11: Gating signals for switches S1 (CH1) and S2 (CH2)

To verify buck-boost operation of Cuk converter with an input of 15V, the results of the developed converter are explained in this section. For duty ratio of 24.8% as shown in Fig. 12 (a), the converter output is observed to be 8.08V which is lesser than 15V. If the duty ratio is 54%, the output voltage is 17.4V that is higher than input voltage of 15V as depicted in Fig. 12 (b). This confirms the Cuk converter functionality over the selected range of duty ratios. In Fig. 12, the channel 1 (CH1) shows S_1 triggering pulse and the inverted polarity Cuk converter output voltage as represented by channel 2 (CH2). Further, the H-Bridge inverter was developed as the second phase for dc-ac conversion. The inverter output voltage is 9V (peak) ac, when the input voltage of 10.5V is applied across its input terminals with modulation index of 0.85. The inverter output voltage is depicted in Fig. 13.



(a)



(b)

Fig. 12: Output of the (a) PWM with 25% duty ratio for S_1 and output voltage, (b) PWM with 54% duty ratio for S_1 and output voltage

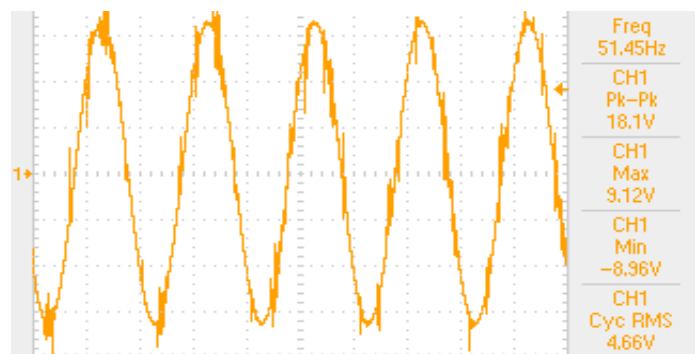

Fig. 13: Cuk based Inverter Output Voltage

7. Conclusion

The hardware prototype of low power dc-ac converter for photovoltaic power sources is implemented in this paper. The PV panel is controlled to extract maximum power from it. The DSP based controller is used for controlling the duty ratio of PWM signals for the switches of Cuk converter and single phase H-bridge inverter. The simulation and the experimental results proved the operational working of the proposed Cuk based single phase inverter. Also this concept can be extended for dc to three phase ac power conversion by paralleling three single phase converters with the same point of common coupling (PCC) of the PV arrays.

References

- [1] R. O. Caceres and I. Barbi, "A boost dc-ac converter: Analysis, design, and experimentation," *IEEE Trans. Power Electronics*, vol. 14, no. 1, pp. 134–141, Jan. 1999.
- [2] R. R. Errabelli and P. Mutschler, "Fault-tolerant voltage source inverter for permanent magnet drives," *IEEE Trans. Power Electron.*, vol. 27, no. 2, pp. 500–508, Feb. 2012.
- [3] M. Jang, M. Ciobotaru, and V. G. Agelidis, "A single-phase grid connected fuel cell system based on a boost-inverter," *IEEE Trans. Power Electron.*, vol. 28, no. 1, pp. 279–288, Jan. 2013.
- [4] B. W. Williams, "DC-to-DC converters with continuous input and output power," *IEEE Trans. Power Electron.*, vol. 28, no. 5, pp. 2307–2316, May 2013.

- [5] Ahmed Darwish, Derrick Holliday, Shehab Ahmed, *Senior Member, IEEE*, Ahmed M. Massoud, *Senior Member, IEEE*, and Barry W. Williams, "A Single-Stage Three-Phase Inverter Based on Cuk Converters for PV Applications" *IEEE Journal of Emerginh and Selected Topics in Power Electronics*, vol. 2, no. 4, pp. 797–807, December 2014.
- [6] M. T. Tsai, C. L. Chu, C. M. Mi, J. Y. Lin, and Y. C. Hsueh, "Designing a Single-Stage Inverter for Photovoltaic System Application" *Mathematical Problems in Engineering*, Volume 2013 (2013), Article ID 912487, 8 pages
- [7] S.Z.Mohammad Noor, Member IEEE, A.M.Omar, N.N.Mahzan, I.R.Ibrahim Universiti Teknologi Mara (UiTM) 40450 Shah Alam, Selangor, "A Review of Single-Phase Single Stage Inverter Topologies for Photovoltaic System" 2013 IEEE 4th Control and System Graduate Research Colloquium, 19 - 20 Aug. 2013, Shah Alam, Malaysia
- [8] H. Patel and V. Agarwal, "MPPT scheme for a PV-fed single phase single-stage grid-connected inverter operating in CCM with only one current sensor," *IEEE Trans. Energy Convers.*, vol. 24, no. 1, pp. 256–263, Mar. 2009.
- [9] Ying-Khai Teh, Student Member, IEEE, and Philip K. T. Mok, Fellow, IEEE, "Design of Transformer-Based Boost Converter for High Internal Resistance Energy Harvesting Sources With 21 mV Self-Startup Voltage and 74% Power Efficiency" *IEEE Journal of Solid-State Circuits*, vol. 49, no 11, November 2014, pp 2694-2704
- [10] Jayalakshmi N. S., D. N. Gaonkar, Adarsh S. and Sunil S., "A Control Strategy for Power Management in a PV-Battery Hybrid System with MPPT" In: 2016 IEEE First International Conference on Power Electronics, Intelligent Control and Energy Systems, DTU, New Delhi, 04/07/2016, pp. 1-6
- [11] T. ESRAM and P. L. Chapman, "Comparison of photovoltaic array maximum power point tracking techniques," *IEEE Trans. Energy Conv.*, Vol. 22, pp. 439–449, 2007.
- [12] H. Patel and V. Agarwal, "MPPT scheme for a PV-fed singlephase single-stage grid-connected inverter operating in CCM with only one current sensor," *IEEE Trans. Energy Convers.*, vol. 24, no. 1, pp. 256–263, Mar. 2009.
- [13] Ioan Viorel Banu, Răzvan Benigua, Marcel Istrate," Comparative Analysis of the Perturb-and-Observe and Incremental Conductance MPPT Methods", 8th International Symposium on Advanced Topics in Electrical Engineering, May 23-25, 2013, pp. 1-4.
- [14] H. S.-H. Chung, K. K. Tse, S. Y. R. Hui, C. M. Mok, and M. T. Ho, "A novel maximum power point tracking technique for solar panels using a SEPIC or Cuk converter," *IEEE Trans. Power Electron.*, vol. 18, no. 3, pp. 717–724, May 2003.
- [15] Arjav Harjai, Abhishek Bhardwaj, Mrutyunjaya Sandhibigraha, Thesis on "Study of Maximum Power Point Tracking (MPPT) Techniques in A Solar photovoltaic array", NIT Rourkela, pp. 1-42, May 2011.