

# Investigation of PVDF-based Micro Ocean Wave Power Generation Capability

Musaddak Maher Abdul Zahra <sup>\*†</sup>, Hairder Sharif <sup>\*\*</sup>, Kadhum Al-Majdi <sup>\*\*\*</sup>, Sanaa Fathy Mahmud <sup>\*\*\*\*</sup>, Hasan Mohammed Abdullah <sup>\*\*\*\*\*</sup>, Mohammed Sellab Hamza <sup>\*\*\*\*\*</sup>, Ahmed A. Ali <sup>\*\*\*\*\*</sup>

\*+ Computer Techniques Engineering Department, Al-Mustaqbal University College, Hillah, Iraq

\*\* College of Medical Technology/ Medical Lab techniques, Al-Farahidi University/Iraq

\*\*\* Department of Biomedical Engineering/ Ashur University College/Baghdad/ Iraq

\*\*\*\* Department of Dentistry, AlNoor University College, Bartella, Iraq

\*\*\*\*\* Department of Optical Techniques, Al-Zahrawi University College, Karbala, Iraq

\*\*\*\*\* Al-Esraa University College, Baghdad, Iraq

\*\*\*\*\* College of Petroleum Engineering, Al-Ayen University, Thi-Qar, Iraq

(First Author Mail Address, Second Author Mail Address, Third Author Mail Address)

<sup>†</sup>Corresponding Author; Musaddak Maher Abdul Zahra, Computer Techniques Engineering Department, Al-Mustaqbal University College, Hillah, Iraq, Tel: +96 7829975667, 786musaddak@gmail.com)

*Received: 23.04.2023 Accepted:02.06.2023*

**Abstract-** A great deal of attention must be paid to the development of NRE, because electricity demand is growing rapidly. For this reason, it is important to continue developing ideas for how to generate electricity in various ways. A piezoelectric material such as PVDF can be used to generate electricity. PVDF material is a piezoelectric material, meaning it is able to convert mechanical energy into electrical energy. This is done by creating an electric field when mechanical stress is applied to the material. This makes PVDF a great option for generating electricity from renewable sources, such as wind or wave energy. By using this technology, we can reduce our dependence on fossil fuels and protect the environment. An electric current rectifier rectifies the electric current released by the PVDF. Current and voltage sensors are used to measure voltage and current values, which are then translated by an Arduino board. Micro SD cards are used to store voltage and current measurements. This research shows that PVDF converts waves' mechanical energy into electrical energy. An impact on a wave will result in an increase in voltage and current generated. It is estimated that on average 2.29 mW of power is generated.

**Keywords:** PVDF, Power Generation, Wave Power

## 1. Introduction

Electrical energy powers our homes, businesses, cars, and appliances and provides us with lighting, heating, and cooling. It is essential for communication and transportation and is needed to make many of the products that we use every day. Electricity is required for almost all human activities today, especially in the era of Industry 4.0 where all internet-supporting devices require electricity [1]. This is because the internet is powered by electricity, from servers to routers to smartphones. In the era of Industry 4.0, devices like sensors, cameras, and other technologies require even more energy than before, in order to be able to transmit and

collect data. Electricity will continue to grow in use, and electrical energy production will grow as well [2]. This increased demand for electricity will require more power plants to be built, which will in turn lead to an increase in the amount of emissions released into the environment. This will have an effect on the climate, making it even more important for us to find ways to reduce the amount of energy we use. The limited availability of renewable energy sources such as solar, wind, and hydro, as well as the high cost of developing and maintaining such sources. Additionally, many governments lack the proper incentives for individuals and businesses to invest in renewable energy sources [3]. In the meantime, non-renewable sources of energy like coal, oil,

and gas will be depleted. As a result, many governments are turning to energy sources that are cleaner and more sustainable in the long run, such as nuclear energy and renewable sources. In addition, governments are providing incentives to encourage individuals and businesses to invest in renewable energy sources, such as subsidies and tax credits. In order to increase the number of equipped power plants, the percentage must continue to increase [4]. This, in turn, will lead to a decrease in emissions of greenhouse gases and other pollutants. Additionally, renewable energy sources are more sustainable and cost-effective in the long run, which is why governments are investing in them. Renewable energy is dominated by solar power plants and hydropower plants. Solar and hydropower plants are more efficient and cost-effective than other renewable energy sources such as wind or geothermal. They also produce less pollution, require less land, and have a smaller environmental footprint than other renewable energy sources [5].

There were two types of PZT used in this study the process of hydropower involves channeling fast-flowing water through turbines and generators to generate electricity. Low-lying areas have a very difficult time applying this concept. Solar and hydropower plants also have the potential to generate a large amount of power in a short amount of time, making them more reliable sources of energy. Additionally, they have the potential to produce power at a lower cost than other renewable energy sources, which makes them more attractive to energy providers [6]. Wave energy is a source of energy rarely considered in coastal areas that are low-lying. While the waves generated by the sea, which covers more than 3 million square meters, can be used to generate energy. It is possible to convert the force generated by waves in the sea into electrical energy by converting the push or pull forces of those waves. PVDF materials with piezoelectric properties have been shown to be useful for converting various types of force into electrical energy, and they can be used for this purpose. Materials of this type are capable of producing electrical energy as a result of various forces applied to them such as pushes, pulls, torques, and vibrations [7]. There is a good level of resistance because it is a flexible material. In addition to that, this material is highly resistant to corrosion, since it is formed from polymers. So it is clear that piezoelectric materials are in the process of becoming one of the power plants that are using new renewable energy. As a power generator, PVDF has been successfully tested by Vatansever et al [8] who performed a study using PZT and PVDF materials as they were investigated as potential power generators [8].

There were two types of PZT used in this study, which are namely the one layer and the bimorph type of PZT. Furthermore, they were also shown to have used two types of PVDF material, both with capacitances of 1.38 nF and 11 nF. It was determined that two natural phenomena could be used as test subjects, raindrops, and wind. According to a study, PZT materials produce more electrical energy (2.29 mW) than PVDF materials. In addition, PVDF material has also been shown to be capable of generating electricity from both natural phenomena. The concept of using piezoelectric materials to generate electricity with wave energy was also

examined by Viet et al. [9] in their research regarding the use of wave energy to generate electricity. The researchers examined the efficiency (62%) of this type of wave power. There was a study in which it was shown plants in comparison with other types of wave power plants [9]. Their research shows that PVDF materials can be used to make power plants with minimal complexity and at a relatively low cost of manufacture as compared to other materials. It is on the basis of this good potential that the research Investigation of the Capability of PVDF-Based Micro Ocean Wave Power Plant has been carried out. This research is aimed at determining the potential of PVDF-based micro-ocean wave power plants in terms of energy output and efficiency. The results of this study will help inform decisions about the viability and feasibility of using this technology in the future. Figure 1. Shows the two types of PZT materials.

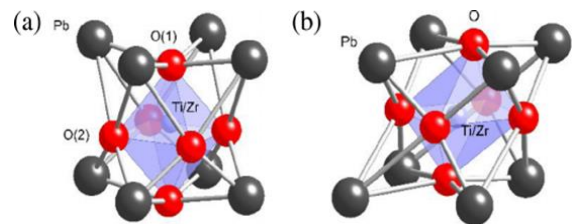

Fig. 1. Two types of PZT materials

## 2. Research Methods

### 2.1 Design of Tools

A galvanized hollow steel frame will be used to support the PVDF sensor, which will be glued onto its four corners. The galvanized hollow steel frame will provide strong and durable support for the PVDF sensor, and gluing the sensor to the corners of the frame will ensure that it is securely attached and will prevent it from shifting or becoming loose. A PVDF sheet is glued to an iron frame to prevent the PVDF material from being swayed and pulled into the ocean [10]. The galvanized steel frame is corrosion-resistant and can withstand the saltwater environment of the ocean, while the PVDF sheet provides an additional layer of protection and prevents the material from being pulled in harsh ocean currents. The glue ensures that the PVDF sheet is secured to the frame, preventing it from shifting or becoming loose. A buoy is also attached to the PVDF's outermost part. In the event of ups and downs in the water, the buoy will help maintain the PVDF in an upright position. The glue provides a strong bond between the PVDF and the frame so that regardless of the movement of the water, the PVDF will remain securely attached to the frame [11]. The buoy also helps to keep the PVDF in an upright position so that it is not affected by the movement of the water. To support data collection, this research also uses an Arduino-based data storage system. The Arduino-based system is able to detect any changes in the position of the PVDF and the frame, and it is also able to store data that is collected from the sensors in the PVDF and the frame. This allows the researchers to monitor the system and make adjustments if necessary. A current rectifier converts the alternating current PVDF voltage to the direct current. This rectifier allows for more precise measurements of the PVDF's displacement and also helps to reduce power consumption [12]. Additionally,

the Arduino-based system is equipped with an algorithm that can detect any abnormalities in the data and alert researchers to any potential issues. An Arduino UNO then converts the result of the conversion by measuring the current and voltage using a current and voltage sensor before storing it in the micro SD. The Arduino UNO then uses the measured current and voltage to calculate the amount of energy that has been used, before storing the result of the calculation in the micro SD. Figure 2 shows the frame design of the system and Figure 3. Shows the Circuit diagram of a generator.

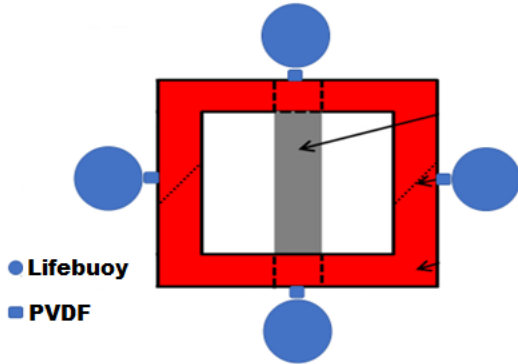

Fig. 2. Frame design

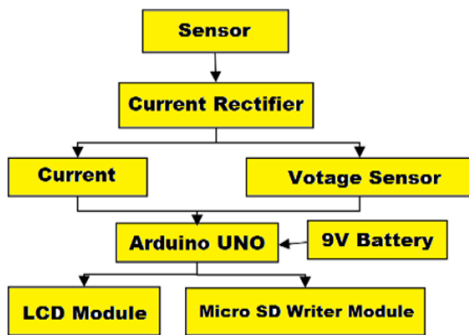

Fig. 3. Circuit diagram of a generator

**3. Tool Making and Material Determination**

A PVDF material has been selected as the main material in this study because it has been designed based on the design that has been made. PVDF has the advantage of being lightweight, strong, and non-corrosive, making it an ideal material for the study. Additionally, its flexibility allows it to be shaped easily, making it useful for applications that require intricate designs and shapes [13]. A PVDF material produced by MEAS measuring 1.5x3 cm and already having piezoelectric properties was used. This made it possible to create a device that was compact and had the capability to generate a large amount of electricity with minimal input. Additionally, the fact that PVDF is non-corrosive meant that the device would not be damaged by environmental factors, making it suitable for a variety of applications. A number of other tools are also needed so that PVDF can be used as a generator as well. There are many supporting tools, including a current rectifier, a current and voltage sensor, an Arduino UNO, an LCD module, a Micro SD module, a 1.5x3, a 9V battery, an iron, welding wire, paint, a laptop, and an oscilloscope [14]. The first step in making the tool is to make the frame first, which is made of galvanized hollow iron that

has been pre-finished. Welding is done by the SMAW welding method, which involves cutting the iron material and then welding it. The frame is then covered with PVDF, current rectifier, voltage and current sensors, Arduino UNO, LCD module, and microSD card.

**4. Testing of Tools**

The tool is checked after it has been completed and is made ready for use. The purpose of this check is to ascertain whether the tool has been made in a way that meets the expectations. This check is important to make sure that the tool has been constructed correctly and is safe for use. It is also important to make sure that the tool is made according to the specifications and meets the quality standards set out by the manufacturer. This ensures that the circuit is working properly by calibrating the output results which will be stored in the micro SD card and checking the circuit's functioning. The calibration process involves comparing the measurement results of the system device with the results of an oscilloscope and also with the results of a multimeter in order to calibrate the device. A programme on the Arduino is adjusted if the measured value does not match the data generated until the difference between the two is less than 0.5%.

**5. Testing and Data Collection**

The research was conducted on the 5th of January 2023 between the hours of 09.00 and 16.00. The research team spent the day gathering data and interviewing participants at the designated location, combining both quantitative and qualitative research methods. Based on the height of the waves, PVDF voltage and current are generated based on the height of the waves [15]. A current rectifier rectifies the PVDF current, and then current and voltage sensors measure the voltage and current. After the data was collected, the research team compiled the data and analyzed it to determine the relationship between the height of the waves and the PVDF voltage and current. The results of the analysis were then compared to the measurements taken by the current and voltage sensors to validate their accuracy. Arduino then converts the current and voltage sensor data for display on the LCD and storage in the microSD card. The voltage graph data is then taken every two hours using an oscilloscope [16]. Table 1 shows the energy resources data in Iraq.

**6. Cost of Energy Generation**

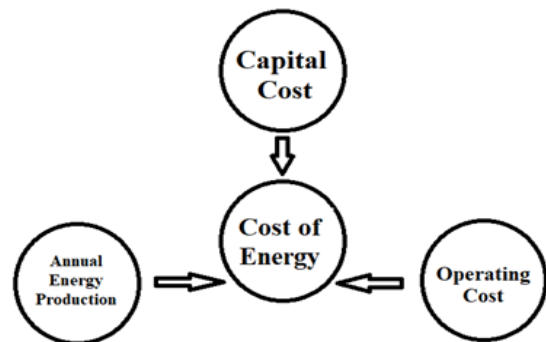

Fig. 4. Factors affecting the cost of energy

Electricity generation costs (COE) are calculated by taking into account all lifetime costs and energy production. An estimate of the cost of power is determined by equating the power production with estimated costs, which yields the cost of power in dollars per kilowatt hour. Figure 4. Shows the factors affecting the cost of energy. The annual energy production (AEP) depends on the site resource, the device's energy capture capabilities, and its availability. The yield of an energy extraction device is important because it determines the cost per kilowatt hour based on how much electricity is generated. The SI OCEAN report 2021 defines the cost of energy as the sum of capital and lifetime operational and maintenance costs divided by lifetime electricity generation to the grid on the assumption that the cost of operating and maintaining (O&M) and power generated is constant each year. The cost of energy is defined by Callaghan and Boud (2006) as follows: PV represents the present value over the product's life. A marine energy device's capital costs, operations and maintenance costs, and performance are all intertwined; improving one may require sacrificing the other. This methodology is used in calculating energy costs in this report. A cost of generation and maintenance may, however, be used to compare the cost of existing installations:

$$\text{Cost of Energy} = \frac{(\text{Capital cost} + \text{PV (O \& M Costs)})}{(\text{PV (Energy production)})}$$

$$\text{Cost of O \& M energy generation} = \frac{(\text{PV (O \& M Costs)})}{(\text{PV (Energy production)})}$$

$$\text{Average generation O \& M} = \text{USD } 222/\text{MWh}$$

$$\text{Maximum generation O \& M} = \text{USD } 522/\text{MWh}$$

**7. Results and Discussion**

Figure 5. shows the voltage output of the sheet, which increased steadily during the duration of the experiment. Figure 6. shows the current output, which remained relatively constant. Figure 7. shows the power output of the sheet, which rose sharply at the beginning of the experiment and then tapered off towards the end. A sheet of PVDF measuring 1.5x3 cm in size was used to measure voltage, current, and power for an interval of 60 seconds. The measurements were taken every second for a period of 60 seconds to determine the voltage, current, and power of the PVDF sheet. At the time of this measurement, the average wave height was 0.27 meters, with the measurement taking place at 08:30. This is likely due to the fact that wave heights tend to be at their lowest during the morning hours before increasing in the afternoon as the day warms up [18]. The following three graphs illustrate that PVDF is such an efficient material that it can generate electricity when exposed to waves in the ocean. In any case, the production of power by PVDF is not constant and it goes up and down depending on the light conditions. The graphs show that when the light intensity is low, the power output is also low, but when the light intensity is high, the power output is high. This is because PVDF is a photovoltaic material, meaning it creates electricity when light strikes it.

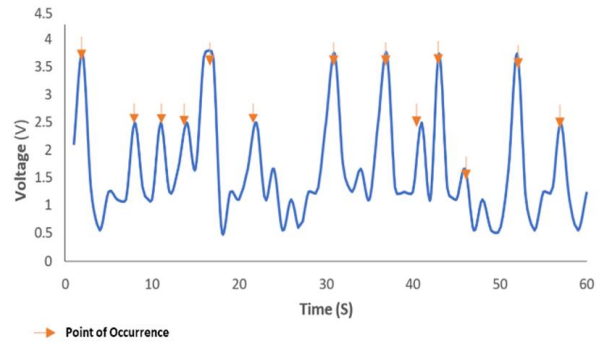

**Fig. 5.** A 60-second measurement of the PVDF voltage

The average voltage generated by PVDF over the course of 60 seconds, as shown in Figure 5, is 1.65 volts. This is due to the fact that the PVDF generates a current when it is in contact with water. The current generated is proportional to the amount of water present, and it is this current that is measured over the course of 60 seconds to determine the average voltage. There is a maximum voltage of 3.75 volts generated by the generator [19]. There is a sharp increase in the PVDF's output voltage when it is struck by waves. The current will increase considerably when the waves hit, as the current increases with the increase in current.

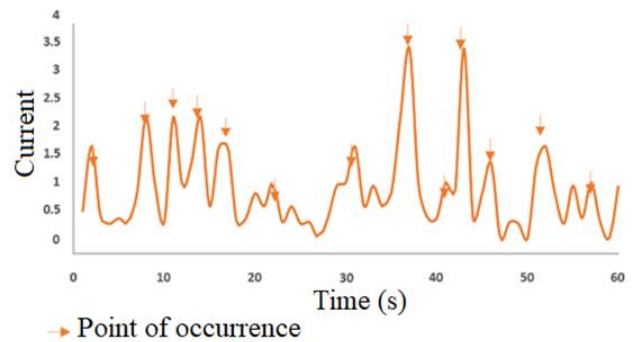

**Fig. 6.** Current measurement results from the PVDF for 60 seconds

Figure 6 shows this in more detail. The PVDF current was tested for 60 seconds and the largest current was 3.4mA. This indicates that PVDF can store a large amount of charge, which is necessary for creating sustained currents. Additionally, the current is relatively stable over 60 seconds, which shows that the material is durable and can handle long-term exposure to charge. As a result, the average current that is released by PVDF for a period of 60 seconds is 1.07 mA on average [20]. This suggests that PVDF is an ideal material for creating sustained currents, as it has the ability to store large amounts of charge, and can withstand long-term exposure to charge without losing its stability. This makes it an ideal material for applications such as energy storage or electrical circuits. A PVDF's power can be calculated using the formula  $P=V.I$ , where P is power, V is voltage, and I is electric current. PVDF is a polymer with a high dielectric constant, making it an excellent material for electrical insulation. It also has low power loss and a low dielectric loss tangent, which means it can store and release energy efficiently. Additionally, it has a high breakdown

voltage and a high thermal stability, making it a great choice for applications such as energy storage and electrical circuits [21].

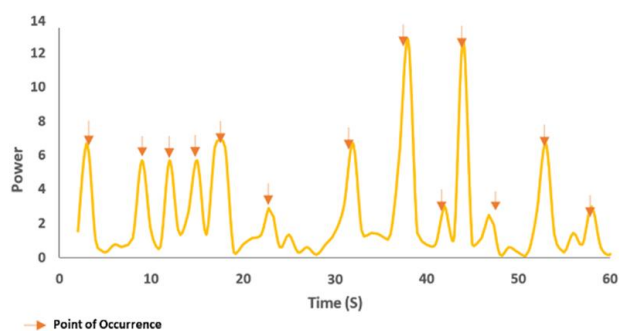

**Fig. 7.** PVDF power measurement results for 60 seconds

The results of the power calculation can be seen in Figure 7 which shows the results. The average power generated by PVDF is 2.29 mW, according to the power calculation results. This indicates that the PVDF material is capable of generating a significant amount of power, which is higher than the power generated by other materials. This suggests that PVDF is an effective material for generating power [22]. A maximum power of 12.8 mW can be generated by this device. From 08.30 to 15.30, voltage, current, and power are measured not only every 60 seconds but also every 30 minutes. According to the measurement results, the highest average voltage was 2.25V, the highest average current was 1.27 mA, and the highest average power was 2.86 mW. The results also show that the device is able to maintain a consistent voltage, current, and power output throughout the day, indicating that PVDF is a reliable material for generating power [23]. The average power measured between 08.30-15.30 is 2.26 mW. The output results using waves are quite good. This indicates that the device is capable of effectively and efficiently converting mechanical energy into electrical energy. The consistent voltage, current, and power output also demonstrate that PVDF is a reliable material for generating power, as the device is able to produce a consistent output despite changes in environmental conditions. PVDF produced from rainfall and wind produces less than 2 milliwatts of power. Table 2. shows the voltage, current, and power Measurements every 30 Minutes.

## 8. Conclusion

This research tested PVDF as a special type of plastic that can generate electricity when exposed to pressure, such as the pressure of waves. The researchers tested the efficiency of PVDF in converting wave energy into electricity. A PVDF sheet is attached to a frame and connected to an Arduino, a sensor, and a data storage device. The research measured the electrical current generated by the PVDF sheet when it was exposed to pressure from a wave created in a wave tank. The data was then analyzed to determine the efficiency of the PVDF sheet in converting wave energy into electricity. The PVDF was hit by waves during the test on the beach. The PVDF can calculate power based on voltage and current produced by the waves. A

wave impact will increase the voltage, current, and power output of the PVDF. It was measured that the average output power was 2.26 mW over 7 hours. It is certainly better than PVDF power generated by raindrops and wind.

## Abbreviations:

New Renewable Energy – NRE  
Polyvinylidene fluoride - PVDF  
Lead zirconate titanate - PZT  
Alternating current - AC  
Direct current - DC  
Liquid Crystal Display - LCD  
Shielded metal arc welding - SMAW  
Shielded metal arc welding - SMAW

## References

- [1] H.G. Yeo, J. Jung, M. Sim, J.E. Jang, and H. Choi, "Integrated piezoelectric AlN thin film with SU-8/PDMS supporting layer for flexible sensor array," *Sensors*, vol. 20, pp. 315-324, 2020.
- [2] S.S Won, H. Seo, M. Kawahara, S. Glinsek, J. Lee, Y. Kim, C.K. Jeong, A.I. Kingon, and S.H. Kim, "Flexible vibrational energy harvesting devices using strain-engineered perovskite piezoelectric thin films," *Nano Energ.*, vol.55, pp.182–192, 2019.
- [3] D. Chen, K. Chen, K. Brown, A. Hang, and J.X.J. Zhang, "Liquid-phase tuning of porous PVDF-TrFE film on flexible substrate for energy harvesting," *Appl. Phys. Lett.*, vol.110, pp. 153902-915, 2017.
- [4] "Ocean Energy Systems (OES) 2014 Annual report," The Executive Committee of Ocean Energy Systems, 1–148, 2014.
- [5] N.Y.W. Zaw, J. Yun, T.S. Goh, I. Kim, Y. Kim, and J.S.L.D. Kim, "All-polymer waterproof triboelectric nanogenerator towards blue energy harvesting and self-powered human motion detection," *Energ.*, vol.247, pp.123422-34, 2022.
- [6] A. Wang, J. Chen, L. Wang, J. Han, W. Su, A. Li, P. Liu, L. Duan, C. Xu, and Z. Zeng, "Numerical analysis and experimental study of an ocean wave tetrahedral triboelectric nanogenerator," *Appl Energy*, vol.347, pp. 118174-85, 2022.
- [7] Z. Jing, J. Zhang, J. Wang, M. Zhu, X. Wang, T. Cheng, J. Zhu, and Z.L. Wang, "3D fully-enclosed triboelectric nanogenerator with bionic fish-like structure for harvesting hydrokinetic energy," *Nano Res*, vol.15, pp.5098–104, 2022.
- [8] D. Vatanserver, R.L. Hadimani, T. Shah, and E. Siores, "An investigation of energy harvesting from renewable sources with PVDF and PZT," *Smart Mater. Struct.*, vol.20, pp.20-31, 2011.
- [9] NV. Viet, N. Wu, and Q.A. Wang, "Review on energy harvesting from ocean waves by piezoelectric technology," *J. Model. Mech. Mater.*, vol.31, pp.321-341, 2017.

- [10] H. Wang, C. Zhu, W. Wang, R. Xu, P. Chen, T. Du, T. Xue, Z. Wang, and M. Xu, "A Stackable Triboelectric Nanogenerator for Wave-Driven Marine Buoys," *Nanomater.*, vol.12, pp.594-608, 2022.
- [11] H. Hong, X. Yang, H. Cui, D. Zheng, H. Wen, R. Huang, L. Liu, J. Duan, and Q. Tang, "Self-powered seesaw structured spherical buoys based on a hybrid triboelectric–electromagnetic nanogenerator for sea surface wireless positioning," *Energ. Environ. Sci.*, vol.15, pp.621–632, 2022.
- [12] H. Wen, P. Yang, G. Liu, S. Xu, H. Yao, W. Li, H.Q.J. Ding, J. Li, and L. Wan, "Flower-like triboelectric nanogenerator for blue energy harvesting with six degrees of freedom," *Nano Energ.*, vol.93, pp.106796-808, 2022.
- [13] G. Ma, B. Li, S. Niu, J. Zhang, D. Wang, Z. Wang, L. Zhou, Q. Liu, L. Liu, J. Wang, Z. Han, and L. Ren, "A bioinspired triboelectric nanogenerator for all state energy harvester and self-powered rotating monitor," *Nano Energ.*, vol.91, pp. 106637-650, 2022.
- [14] H. Hong, X. Yang, H. Cui, D. Zheng, H. Wen, R. Huang, L. Liu, J. Duan, and Q. Tang, "Self-powered seesaw structured spherical buoys based on a hybrid triboelectric–electromagnetic nanogenerator for sea surface wireless positioning," *Energy Environ Sci*, vol.15, pp.621–32, 2022.
- [15] H. Liu, F. Yan, Y. Jin, W. Liu, H. Chen, and F. Kong, "Hydrodynamic and Energy Capture Properties of a Cylindrical Triboelectric Nanogenerator for Ocean Buoy," *Appl. Sci.*, vol.11, pp.3076-85, 2021.
- [16] Y. Feng, X. Liang, J. An, T. Jiang, and Z.L. Wang, "Soft-contact cylindrical triboelectric electromagnetic hybrid nanogenerator based on swing structure for ultra-low frequency water wave energy harvesting," *Nano Energ.*, vol.18, pp.105625-638, 2021.
- [17] J. Callaghan, and R. Boud, "Future marine energy. Results of the marine energy challenge: Cost competitiveness and growth of wave and tidal stream energy," *Carbon Tru. Rep.*, 2006.
- [18] B. Zhao, Z. Li, X. Liao, L. Qiao, Y. Li, S. Dong, Z. Zhang, and B. Zhang, "A heaving point absorber-based ocean wave energy convertor hybridizing a multilayered soft-brush cylindrical triboelectric generator and an electromagnetic generator," *Nano Energ.*, vol. 89:106381, 2021.
- [19] F. Zheng, Y. Sun, X. Wei, J. Chen, Z. Yuan, X. Jin, L. Tao, and Z. Wu, "A hybridized water wave energy harvester with a swing magnetic structure toward intelligent fishing ground," *Nano Energ.*, vol.90, pp.106631-648, 2021.
- [20] H. Wu, Z. Wang, and Y. Zi, "Multi-mode water-tube-based triboelectric nanogenerator designed for low-frequency energy harvesting with ultrahigh volumetric charge density," *Adv. Energ. Mater.*, vol.32, pp.2100038-043, 2021,
- [21] N.Y.W. Zaw, J. Yun, T.S. Goh, I. Kim, Y. Kim, S.J. Lee, and D. Kim, "All-polymer waterproof triboelectric nanogenerator towards blue energy harvesting and self-powered human motion detection," *Energ.*, vol.247, 123422-432, 2022.
- [22] H. Wang, L. Xu, and Z. Wang, "Advances of high-performance triboelectric nanogenerators for blue energy harvesting," *Nano energy. Adv.*, vol.1, pp.32–57, 2021.
- [23] W. Sun, Y. Zheng, T. Li, M. Feng, S. Cui, Y. Liu, S. Chen, and D. Wang, "Liquid-solid triboelectric nanogenerators array and its applications for wave energy harvesting and self powered," *Energ.*, vol.217, 119388, 2021.

Energy sources	Total in Iraq (bnkwh)	Percentage in Iraq	Per capita in Iraq (kwh)
Fossil Fuels	243.05	97.8	5.582
Nuclear power	0.00	0.0	0.00
Solar Energy	248.51	0.1	5.71
Wind power	0.00	0.0	0.00
Water power	5.22	2.1	119.88
Tidal power plants	0.00	0.0	0.00
Geothermic	0.00	0.0	0.00
Biomass	0.00	0.0	0.00

Hours	After PVDF			Before PVDF		
	Voltage (V)	Current (mA)	Power (Mw)	Voltage (V)	Current (mA)	Power (Mw)
08.30	2.06	1.08	2.25	1.08	0.10	1.23
09.00	2.24	1.28	2.87	1.26	0.30	1.85
09.30	2.06	1.06	2.20	1.08	0.08	1.18
10.00	1.95	1.13	2.19	0.97	0.15	1.17
10.30	1.96	1.04	2.02	0.98	0.06	1.00
11.00	1.84	1.33	2.44	0.86	0.35	1.42
11.30	2.16	1.00	2.16	1.18	0.02	1.14
12.00	1.84	1.17	2.15	0.86	0.19	1.13
12.30	2.06	1.18	2.41	1.08	0.20	1.39
13.00	2.14	0.91	1.97	1.16	0.93	0.99
13.30	2.26	0.88	1.97	1.28	0.90	0.99
14.00	2.04	1.01	2.11	1.06	0.03	1.13
14.30	2.08	1.08	2.23	1.10	0.10	1.25
15.00	2.14	1.04	2.25	1.16	0.06	1.27
15.30	2.13	1.28	2.68	1.15	0.30	1.66
<b>Average</b>	2.06	1.10	2.26	1.08	0.25	1.25