

Optimization and Performance Evaluation of Hybrid Renewable System for Minimizing CO₂ Emissions in Libya: A Case Study

A.M. Elbreki^{1,2}, Hazim Moria^{3,†}, Ahmed M. Ahmed⁴, Monaem Elmnifi⁵, Ahmed Abdulmula²

¹College of electrical and Electronic Technology-Benghazi, Libya

²Solar Energy Research Institute (SERI), Universiti Kebangsaan Malaysia, Malaysia

³Department of Mechanical Engineering Technology, Yanbu Industrial College, Yanbu Al-Sinaiyah City 41912, Kingdom of Saudi Arabia

⁴Renewable Engineering Department, Libyan academy Benghazi, Benghazi, Libya

⁵Department of Mechanical Engineering, Bright Star University, Libya

(nasirburki2013@gmail.com, moriah@rcyci.edu.sa, hazimmoria@gmail.com, follow.bhiri@gmail.com, abdulmula@yahoo.com, monm.hamad@yahoo.co.uk)

[†]Corresponding Author; Hazim Moria, Department of Mechanical Engineering Technology, Yanbu Industrial College, Yanbu Al-Sinaiyah City 41912, Kingdom of Saudi Arabia, Tel: +966 562 262 677, moriah@rcyci.edu.sa, hazimmoria@gmail.com

Received: 20.08.2020 Accepted: 19.09.2020

Abstract- The current study focuses on reducing CO₂ emissions by developing and integrating a grid-based hybrid renewable energy system consisting of solar and wind or hybrid power system. Libya can generate developed economic power and provide electricity as a case study to the modern University of Benghazi in Libya using HOMER to scale and model the power system and assess its feasible solution and economic cost. Under different grid tariff scenarios, a simulation process of the four proposed grid tariff prices scenario. In scenario A with a grid tariff of 5 cents, the optimal system was only for the local grid with an NPC of USD 41.824. Although in scenario B, with a grid tariff of 10 cents and an NPC of USD 83,651. There was no improvement in the optimum system, and only the best-proposed system was the local grid. For scenario C, with a grid tariff of 15 cents, the optimum framework was USD 115.896 for the NPC wind/grid. Whereas in the last scenario D, with a grid tariff of 20 cents, the optimum wind/grid device with NPC was also found at USD 136.081. Among the four scenarios, scenario C minimizing the optimum case CO₂ emissions by 50% compared to the grid-only system in scenario A.

Keywords Hybrid PV-Wind, Cost of Energy, Net Present Cost, Renewable Energy, CO₂ Reduction.

Nomenclature

CO ₂	Carbon Dioxide	NPC	Net Present Cost
SO ₂	Sulfur Dioxide	OPEC	Organization of Petroleum Exporting Countries
COE	Cost of Energy	GHG	Greenhouse Gas
NO _x	Nitrogen Oxides	O&M	Operations and Maintenance
IRR	Internal Return Rate	HRES	Hybrid Renewable Energy Systems

1. Introduction

Libya is a country located in the North African Maghreb region and is the 16th largest country bordered by the Mediterranean Sea, with almost 1.8 million square kilometers. A population is not exceeding six million people. Libya has the 10th largest proven oil reserve in the world, with every region. As an OPEC member, oil reserves' sale reaches 48 billion barrels of oil [1]. Among all other depletion resources, Libya has a great deal of effort in non-

depletion resources such as renewable energy. Libya has been badly affected in all sectors and faced declining revenues from the oil sector, the primary income source. Renewable energies are a universal path for seeking an alternative energy source, protecting the environment, and reducing pollution like CO₂. The annual solar radiation is 2300 KWh/m²/year, and the sunshine is 3500 hrs/year [2]. The average wind speed is around 7.5 m/s. After a revolution, most business sectors experienced a blackout, causing people and economic development to suffer much.

This inadequate power generation reflected mainly on institutions and universities, mainly dependent on on-grid utility as the primary energy source. Hence, the study addresses the possibility of installing a hybrid power generation system to modern Benghazi University as a case study. For private business sectors, start to experiment with implementing renewable energy resources to fulfill load demands in primary grid failure. Simultaneously, it reduces CO₂ emissions and supplies the university load under different circumstances, based on a different local grid scenario. HOMER Pro was selected as a simulation tool to optimize the project. It has an accuracy to scale, model, and simulate the proposed design and optimize the data based on accurate input parameters. Also, find the technically and economically feasible solution based on the lowest NPC and COE. Therefore, the objectives of the study will:

- Analyze the wind and solar potential at the geographical University site by gathering data from various sources.
- Use HOMER software to design and scale the wind-solar hybrid system for the selected University site.
- Study wind-solar hybrid power generation network economic research.
- Reduce CO₂ emissions and protect the environment by using various local grid tariff scenarios to find the best on-grid renewable energy system to meet the specified load demands without interruption.

Abdelsalam et al. [3] built a standalone solar-wind power system for irrigation. The study's objective was to calculate the power demand in the Toshka region for the combined irrigation and domestic load. The sizing of the hybrid system components and the economic feasibility were investigated using MATLAB and Homer. They concluded that the sizing of the hybrid system satisfactorily agreed with that obtained through the homer program. Saheb-Koussa et al. [4] carried out an economic and environmental analysis in the arid region for a grid-connected hybrid system. A comparison between a grid-connected and regular grid service was drawn to focus on the environment and economic impacts. Compared to the grid system alone, the integrated hybrid system has succeeded in reducing COE. The CO₂, SO₂, NO_x emissions have decreased to less than 40% of the conventional grid power system with the benefit of rising wind speed, minimizing the hybrid system's NPC, COE, and emissions. Glaisa et al. [5] used Homer software to evaluate the techno-economic study of a hybrid system powering a school in Misurata City under various potential configurations. The simulation results indicated that the school's electricity supply was provided by the hybrid system most economically and ecologically. Because of the heating, winter consumption is higher than in other seasons. The surplus power from the hybrid system can be sold back to the local grid in the other seasons and reduce the electricity bill, or instead, be used as an advantage in other applications. Siddique et al. [6] proposed a cost-effective solution to combine an existing diesel power plant with a hybrid system that acts as a standby system. The system's renewable initial capital cost is high, but it provides the lowest COE than the diesel generator. There are several advantages of hybrid

energy systems that can minimize losses, boost ecosystems, and lowest O&M costs. In the same sense, Alamari and Iqbal [7] designed the hybrid framework for a house in Libya.

The study presented a concept, using Homer software, a hybrid wind-solar system in Tripoli, Libya. The NPC was used to choose the best-operating conditions; the optimum configuration was chosen for the lowest NPC. Park et al. [8] investigated green power generation systems for South Korea's global campus at Kyung-Hee University. Based on simulation findings, the Homer software shows that building a grid-connected renewable power system is more effective than establishing a grid-free system. Hassan et al. [9] have optimized a hybrid power system for PV/Wind/Diesel using Homer for rural electrification. The simulation results showed that the renewable system could produce a good profit with rational investments due to the amount of renewable energy produced. They mentioned the wind resources; supplying the electricity to a wind turbine is not considered feasible. Swarnkar et al. [10] applied HOMER to optimize the technical institution's hybrid energy system.

The renewable on-grid system is ideal for use with an emissions reduction. Due to the high cost relative to the PV system, a small wind turbine is not feasible with the connective grid system, but without a grid system, the system is not feasible due to high costs. However, the system may be feasible because of high renewable penetration if the battery has been removed to reduce the total cost. A hybrid standalone renewable energy system was developed by Fulzele and Daigavane [11] as a case study. The simulation results suggested that the inverter's hybrid device consisting of 225 KW PV-panels, 50 KW wind generator, 2500 units of batteries, and 150 KW would be an economical solution for generating electricity for rural use. A standalone hybrid power system using HOMER was studied by Navamani [12]. A contrast was made using a 15-year on-grid hybrid system. The COE is still higher than the grid due to the hybrid system's excess energy. The only way to minimize the expense by selling it back to the grid is to need many spaces and proper maintenance regularly, the biggest downside of this method. Research on the techno-economic optimization of wind-solar turbine systems for the remote mosque highway in the Kingdom of Saudi Arabia was carried out by Moria [13]. The simulation results proved that all renewable resources in each remote mosque supported energy conservation and alternatives to fossil fuels and helped eliminate greenhouse gas emissions. Jenkins et al. [14] used HOMER simulation. A grid-connected hybrid wind and solar power generation system designed for a specific position in the Libyan Marj area coastal belt Benghazi. The simulation was calculated to install ten 100 kW wind turbines and 150 kW solar PV arrays as a more economical design feasible to provide an average grid-connected load as the design's payback period was 2.6 years. The energy-saving CO₂ reduction was 0.427 gigawatt-hours 331 tons/year and 1.5-0.74 tons per year for SO₂ and NO_x. Table 1 summarizes some critical literature review papers. Moreover, several published articles also used HOMER as a simulation tool in their studies and analysis of smart renewable energies [15-24].

Table 1. Summarized the most critical literature review papers

Reference/ Paper Title	Schematic by Homer	Findings
<p>[3] A Solar-Wind Hybrid Power System for Irrigation in Toshka Area</p>		<p>The optimum solution after ten the configuration in homer was PV, wind, and battery.</p>
<p>[4] Economic and environmental analysis for grid-connected hybrid photovoltaic-wind power system in the arid region</p>		<p>The sensitivity analysis indicates that under the meteorological conditions in the Adrar area PV-wind HRES is practicable. The NPC, COE, and emissions of the hybrid renewable energy system decrease with the rise in wind speed, and the renewable fraction increases.</p>
<p>[5] Potential of Hybrid System Powering School in Libya</p>		<p>Due to heating, the load profile in winter is far higher than in other seasons, and when renewable resources are small, the optimal solution is PV/wind/diesel generator/battery. The surplus electricity can be used in other applications or sold to the power grid to reduce energy costs.</p>
<p>[6] Optimal integration of hybrid (wind-solar) system with diesel power plant using HOMER</p>		<p>The proposed renewable energy system's initial capital cost is high, but it provides the lowest cost per kWh than the current diesel network. PV/wind/diesel system is recommended for the load shedding hours. The combination of wind, diesel, and grid is found to be more feasible when the site is connected to the grid. The lowest of these is COE. Despite the high load, demand was not possible for off-grid.</p>

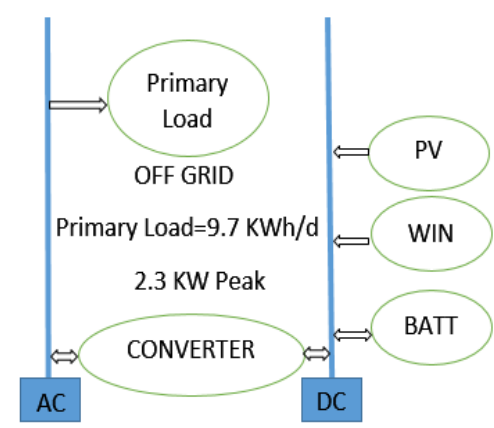
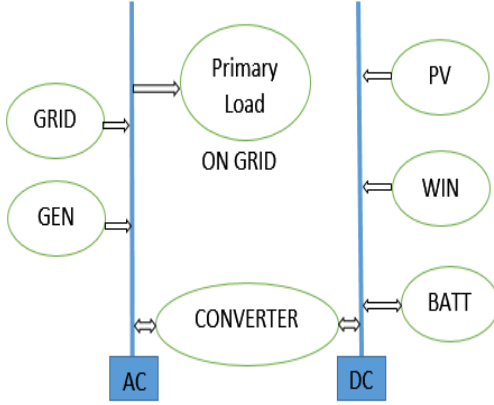
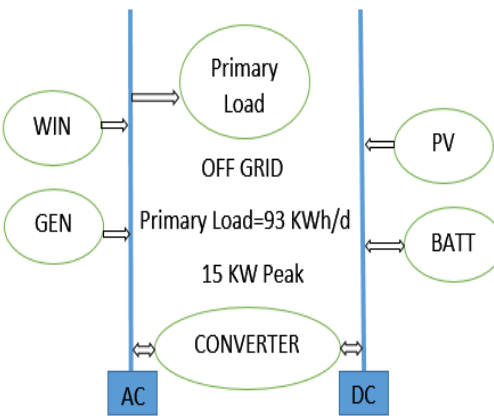
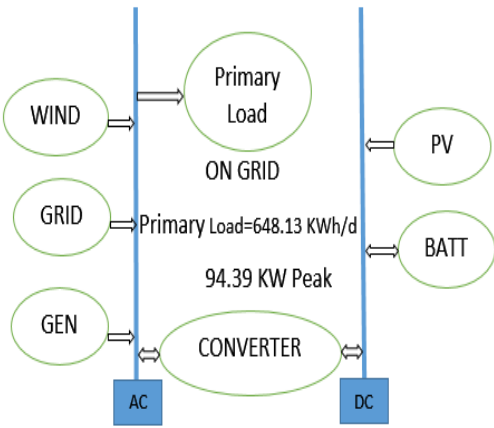
Reference/ Paper Title	Schematic by Homer	Findings
<p>[7] Sizing of a Hybrid Power System for a House in Libya</p>		<p>The NPC has been chosen as the best-operating conditions in light of a network consisting of photovoltaics, wind turbines, battery and converter systems. The lowest NPC of the various options was selected as the best configuration. The findings indicate that a house should have such a hybrid renewable energy network off-grid because it can supply electricity to the home.</p>
<p>[8] Solutions for optimizing renewable power generation systems at Kyung-Hee University's Global Campus, South Korea</p>		<p>Results from simulated scenarios, creating grid-connected renewable power generation systems, are more efficient than establishing grid-free systems. Considering that the grid system currently provides electricity at the campus</p>
<p>[9] Optimization of PV/Wind/Diesel Hybrid Power System in HOMER for Rural Electrification</p>		<p>The hybrid power system simulation PV/wind/diesel has shown a good profit with a reasonable investment due to the renewable energy generated.</p>
<p>[10] An application of HOMER Pro in optimization of hybrid energy system for electrification of technical institute</p>		<p>The study was performed with a grid and without a grid. The cost of energy with a grid-connected system is lower than that without a grid connection, as storage cost decreases can make a hybrid system feasible.</p>

Reference/ Paper Title	Schematic by Homer	Findings
<p>[11] Design of hybrid PV-wind standalone renewable energy system: Case study</p>		<p>The hybrid energy system that provided the lowest NPC and CoE was the feasible solution from the optimizing tests.</p>
<p>[12] Hybrid Power System Design using Homer Pro</p>		<p>A direct comparison with the grid was made for 15 years. Although the COE of the hybrid system is higher than the grid because of excess energy, the energy we produce returns to the grid, the government pays us off, and the overall cost is reduced. The critical machine drawback required many spaces and frequent maintenance.</p>
<p>[13] Techno-Economic Optimization of Solar/Wind Turbine System for Remote Mosque in Saudi Arabia Highway: Case Study</p>		<p>The optimum findings indicate that the high potential solar radiation and wind speeds have contributed to the lowest COE and NPC solar hybrids with wind turbines. In Saudi Arabia, particularly in remote areas, the proposed configuration system contributed to a broad renewable energy application.</p>
<p>[14] Hybrid Power Generation by Using Solar and Wind Energy: Case Study</p>		<p>Through this study, insight was given into the energy situation and renewable energy potential in Libya. The results indicate that Libya has an intense solar radiation intensity in most Libyan regions and wind speed and coastal cities.</p>

2. Design Components and Proposed Grid Tariff Scenarios

2.1. Load Demand

This study is being conducted at a private business university in Benghazi, Libya, which includes 20 classrooms, five offices, three water circulation toilets, two computer labs, and one library. The loads were estimated based on the planned working hours from 7 am to 6 pm, in which approximately 11 hours were consumed. The seasonal load assessment was carried out on the Libyan public electricity company's electricity bill for 2019 (Fig. 1). In HOMER, 20% was considered and added to the primary load for the potential expansion. Table 2 indicated the large loads for lighting and cooling systems in modern Benghazi University.

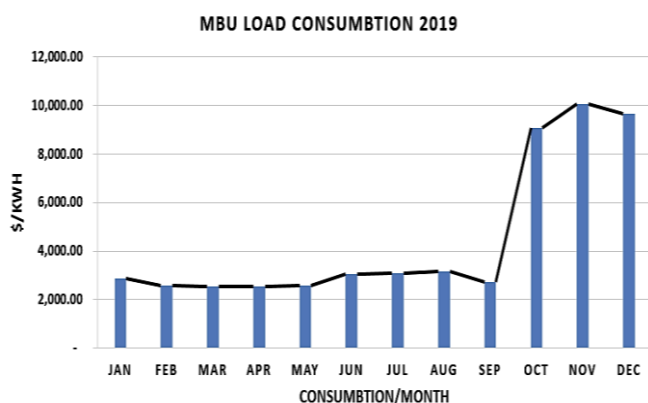

Fig. 1. Load profile and consumption of modern Benghazi University in year 2019.

Table 2. Number of equipment considered in this study

SN	Load Type	No. of Units
1	A/C	21
2	Lighting	433
3	PC's	51
4	LCD screen	2
5	Wall heater	3
6	Printers	8
7	Network switch	1
8	Fridge	2
9	Electronic gate	2
10	Data show	3
11	Photocopier	3

2.2. Meteorological Data

The NASA surface weather and solar energy databases were downloaded from HOMER tools for wind and solar resources. The university's average wind speed was 5.23 m/s to 6.79 m/s with an annual average site location of 6.03 m/s (latitude 32° 03 '49' N and longitude 20° 05 '17.2' E). The total solar radiation ranges between 2.63 kWh/m²/day and 7.94 kWh/m²/day with an annual average of 5.44 kWh/m²/day. The overall clearness indices are 0.618. The average monthly index of solar radiation and clarity is illustrated in Fig.2 and Fig.3.

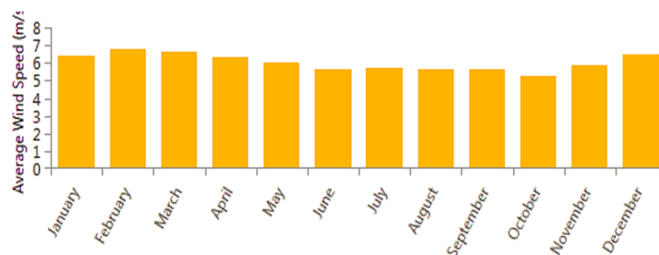

Fig. 2. Monthly average wind speed data.

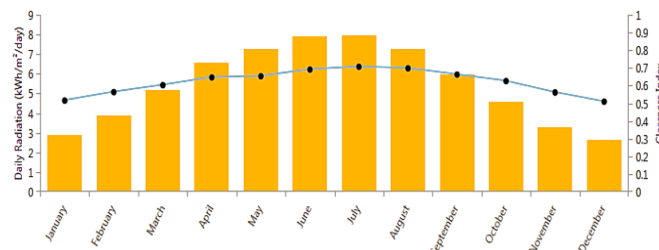

Fig. 3. Monthly averaged solar radiation and clearness index.

2.3. Components Selected in HOMER

All considered components used and the proposed design schematic are presented in Fig.4 and Table 3.

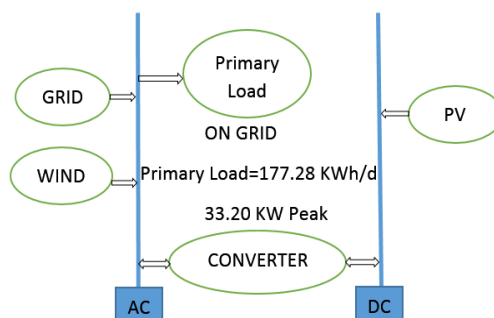

Fig. 4. Schematic configuration of hybrid system using HOMER.

Table 3. Power system components considered by HOMER

Component	Size (kW)	Capital	Replace	O&M (\$/yr)	Lifetime (yr)
Wind	25	45,000 \$/UNIT	30,000 \$/UNIT	800	25
PV	1	2750 \$/KW	1500 \$/KW	100	25
Converter	4	640 \$	640 \$	0	15

2.3.1. Wind Turbine

According to the local and global markets, the capital cost includes installation, transportation, delivery, implementation, and technical costs.

2.3.2. Solar Panels

A mono-crystalline silicon PV module/335W was selected for the size and cost, as shown in Table 3. With 2%,

productivity is selected from the 25-year HOMER library. A 5 kW of PV array system project construction will be USD 12,750, with operating and maintenance costs at 1 % of the total investment cost. The derating factor is 90% over a lifetime of 25 years, and the temperature effects on solar arrays have been considered.

2.3.3. Converter

Based on system design, an inverter is required to convert DC components to serve the AC load. The model selected from the HOMER library is a system converter, which is manufactured by generic; a lifetime is 15 years, its efficiency about 90%. The initial capital cost, including (wiring, panel, mounting hardware), is about 640USD/KWh. The replacement cost is assumed 640 USD/KWh; the O&M cost is zero.

3. Results Analysis

This design's economic input parameter is needed for the HOMER simulation, including the annual real interest rate and project lifetime. Assumed project lifetime is 25 years, 8% and 2% respectively of the HOMER software selected the annual real interest rate and the inflation rate as the default value.

3.1. Simulation Results

Grid electricity price has four different scenarios, ranges between 5,10,15,20 cents were taken in our consideration, and the HOMER optimizer optimize PV system capacity in the selected location from zero to 200 kWh. The number of wind turbines varies from zero to one (i.e., with and without a turbine). The HOMER optimizer has sized the converter to be in the range from zero to 10 KW. The simulation scenarios are summarized in Table 4.

Table 4. Grid scenario tariffs and system design components

Scenario	Grid Tariff (cents)	System Design and Component		
		PV	Wind	Converter
A	5			
B	10	Sized by HOMER	25 kW	Sized by HOMER
C	15			
D	20			

3.2. Optimization Results

Four scenarios with different grid tariff prices are simulated, and the optimization results of each scenario are presents and discussed below:

3.2.1. Scenario A

The price of the grid tariff was 5 cents. The optimum case with the lowest NPC is the electricity grid due to its lowest COE compared to the renewable system COE. This configuration has a COE of 0.05 USD/kWh and an NPC value of USD 41,825. The electricity subsidy in Libya still negatively affects the energy costs and emissions compared

to the renewable system, which was USD 95,874. Detailed about the scenario A results can be found in Appendix A.

3.2.2. Scenario B

In this case, the grid tariff price was 10 cents. The optimum case with the lowest NPC is still the grid due to its lowest COE compared to the renewable system COE. This configuration has a COE of 0.10 USD/kWh and an NPC value of USD 83,651. Again, the electricity subsidy in Libya still negatively affects energy cost and emissions compared to the renewable system, which NPC was USD 116,058. Detailed about the scenario B results can be found in Appendix B.

3.2.3. Scenario C

Meanwhile, at grid tariff price was 15 cents. The optimum case with the lowest NPC is the wind/grid due to its lowest COE compared to grid COE. This configuration has a COE of 0.0782 USD/kWh and an NPC value of USD 115,896 (optimum case) compared to the renewable system in which NPC was USD 136,242. Detailed about the scenario C results can be found in Appendix C.

3.2.4. Scenario D

At grid tariff price was 20 cents. The optimum case with the lowest NPC is the wind/grid system due to its lowest COE compared to grid COE. This configuration has a COE of 0.0918 USD/kWh and an NPC value of USD 136,081. The above scenarios are summarized in the following Tables compared to the renewable system, which NPC was USD 156,426. Detailed about the scenario D results can be found in Appendix D.

Among the four scenarios, the optimum case that has the lowest NPC and COE is shown in Table 5. It noticed that scenario C is the first scenario with renewable energy resources with 25 kW wind turbines and a grid, giving the cheapest configuration. This configuration has a COE of 0.0782 USD/kWh and an NPC value of USD 115,896 when the grid sales tariff is 15 cents/kWh.

Table 5. Summarized scenarios and selected optimum case

Scene.	Grid Tariff (cents)	Dis. & Inf. Rate	COE (\$)	NPC (\$)	Config.	Opt. Case
A	5		0.05	41,825	Grid	
B	10	8%	0.1	83,651	Grid	
C	15	and 2%	0.0782	115,896	Wind/Grid	Selected case
D	20		0.0918	136,081	Wind/Grid	

The total annual power generation from the wind/grid system is 114,712 KWh/y, where wind contributes 83,484 KWh/y with a 72.8% renewable fraction. The annual operation and monthly production details obtained from HOMER are given in Fig. 5 and Table 6.

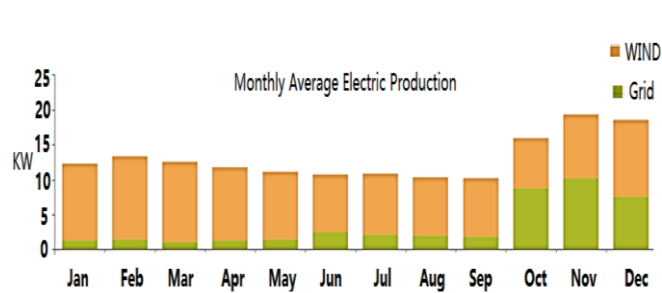

Fig. 5. Monthly average power production by selected case.

Table 6. Number of equipment considered in this study

System	kWh/yr	% Production
Wind Turbine Production	83,484.00	72.8
Grid Purchases	31,228.00	27.2
Total	114,712.00	100

4. Environmental Impact

This research aims to reduce emissions and protect the environment. Several forms of emissions are produced from conventional sources, including CO₂ emissions, SO₂, and NO_x. CO₂ is the largest component of conventional electricity generation pollution and can be considered the most massive environmental impact of the power industry. By contrast, the amount of CO₂ produced by the grid-only system was 40,895 kg/yr CO₂, 177 kg/yr of SO₂, and 86.7 kg/yr of NO_x. The wind/grid system, by comparison, was 19,736 kg/yr of CO₂, 85,6 kg/yr of SO₂, and 41,8 kg/yr of NO_x. Therefore, reducing CO₂ from energy savings will be 21.159 kg/y, with SO₂ and 91.445 tons/year of NO_x. Remark that, emissions reduced by almost half.

5. Financial Evaluation

The project's financial feasibility was examined using a simple payback method. The payback period is when it takes to repay the original investment return for return on the investment. In this context, the initial investment is the sum of all investments related to the wind/grid network's purchase and installation. The return is the income generated at the end of the project lifetime by sales of electricity or component salvage value, reduced by the operating and maintenance costs. Fig. 6 indicated the optimum cost of the case and the income distributed throughout the project lifetime

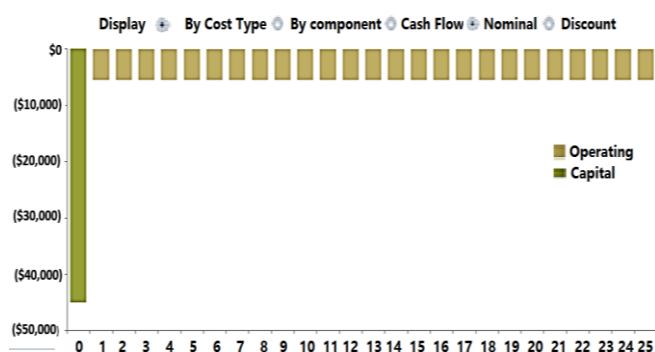

Fig. 6. Distributed cost and income over the project lifetime.

- The total production capacity of the design system = 83,484 kWh/year;
- Initial investment = USD 115,896.30;
- Simple payback period = 10.66 years;
- Internal Return Rate = 8%.

Compared to the base case grid, the optimum case wind/grid with the lowest COE and NPC when the grid power tariff is 15 cents, which have a specific recovery period of no more than ten years. Components of projects such as wind turbines have a 25-year lifetime, the same as the 25-year economic project life. When the grid electricity tariff is 15 cents/kWh relative to the grid system's very high-energy cost alone, this investment is profitable. It also accomplished the goal by reducing emissions and increasing the penetration of renewable.

6. Conclusion

The current study investigated the renewable energy systems that supplied a load of the modern University of Benghazi. Four different grid tariff scenarios were simulated and optimized using HOMER. The standard financial software parameters related to the 8% and 2% discount rate and inflation rate were considered. Homer identified several feasible solutions to the winning case (solution) for each scenario implemented and will be the lowest NPC and COE. Homer simulated these inputs in scenario A, a 5-cent grid tariff used in a simulation, to work out the feasible solutions and optimize them for the lowest NPC and COE. The optimization results showed that scenario A is the winning case among other configurations with the main grid configuration only without any renewable resources. Since it obtained the lowest NPC=\$41,825, COE=\$0.05, and CO₂ emissions were 40,895kg/year. The grid tariff in scenario B was double of scenario A. The optimizer also selected the winning case without any renewable energy as the main grid. Since NPC= \$83,651 is the lowest, COE=\$0.10 and CO₂ emissions were 40,895 kg/year. As for scenario C, the grid tariff was scenario A triple, 15 cents. Under the wind/grid configuration as a winning scenario, the optimizer considers a renewable resource with the main grid as a workable solution. However, this scenario had the lowest NPC and COE, \$115,896, \$0.0782 respectively, and CO₂ emissions were 19,736 kg/year, among other feasible solutions. In the last case, D. When scenario A was a grid, tariff four times, 20 cents. Homer optimizer also found scenario D to be a winning case with a wind/grid setup but with NPC=\$136,081, COE=\$0.0918, and 19,736 kg/year CO₂ emissions. Based on the selection criteria, the study looked for a system configuration that combines the main grid with renewable resources to serve the electric charge and reduce greenhouse gas (GHG) emissions by 50%. This setup should also have the lowest NPC and COE. With a local grid electricity tariff of 15 cents, the third scenario C was selected from the above winning scenarios. It is considered the most effective system with a renewable resource that can reduce GHG emissions and has the lowest NPC and COE by 19,736 kg/yr, \$115,896, and \$0.0782 KWh, respectively.

References

- [1] Oil NOW. World's largest oil reserves by country. 2020 May 12; Available from: <https://oilnow.gy/featured/worlds-largest-oil-reserves-by-country/>.
- [2] A.Khalil, & A. Asheibe, (2015). The chances and challenges for renewable energy in Libya. In the Proceedings of the Renewable Energy Conference (pp. 1-6).
- [3] M.Abdel-Salam, A.Ahmed, H.Ziedan, K. Sayed, M. Amery, & M. Swify, (2011). A solar-wind hybrid power system for irrigation in toshka area. In 2011 IEEE Jordan Conference on Applied Electrical Engineering and Computing Technologies (AEECT) (pp. 1-6). IEEE.
- [4] D. Saheb-Koussa, M. Koussa, M. Belhamel, & M. Haddadi, (2011). Economic and environmental analysis for grid-connected hybrid photovoltaic-wind power system in the arid region. *Energy Procedia*, 6, 361-370.
- [5] K. Glaisa, M. Elayeb, & M. Shetwan, (2014). Potential of hybrid system powering school in Libya. *Energy Procedia*, 57, 1411-1420.
- [6] M. Siddique, A. Ahmad, M. Nawaz, & S. Bukhari, (2015). Optimal integration of hybrid (wind-solar) system with diesel power plant using HOMER. *Turkish Journal of Electrical Engineering & Computer Sciences*, 23(6), 1547-1557.
- [7] G. Alamri, & T. Iqbal, (2016). Sizing of a hybrid power system for a house in Libya. In 2016 IEEE 7th Annual Information Technology, Electronics and Mobile Communication Conference (IEMCON) (pp. 1-6). IEEE.
- [8] E. Park, & S. Kwon, (2016). Solutions for optimizing renewable power generation systems at Kyung-Hee University's Global Campus, South Korea. *Renewable and Sustainable Energy Reviews*, 58, 439-449.
- [9] Q. Hassan, M. Jaszczur, & J. Abdulateef, (2016, September). Optimization of PV/wind/diesel hybrid power system in homer for rural electrification. In *Journal of Physics: Conference Series* (Vol. 745, No. 3, p. 032006). IOP Publishing.
- [10] N. Swarnkar, L. Gidwani, & R. Sharma, (2016, April). An application of HOMER Pro in optimization of hybrid energy system for electrification of technical institute. In 2016 International Conference on Energy Efficient Technologies for Sustainability (ICEETS) (pp. 56-61). IEEE.
- [11] J. Fulzele, & M. Daigavane, (2018). Design and optimization of hybrid PV-wind renewable energy system. *Materials Today: Proceedings*, 5(1), 810-818.
- [12] J. Navamani, A. Lavanya, C. Prahadheeshwar, & S. Riyazudeen, (2019). Hybrid power system design using Homer Pro. *Int. J. Recent Technol. Eng.*, 8, 4.
- [13] H. Moria, (2019). Techno-Economic Optimization of Solar/Wind Turbine System for Remote Mosque in Saudi Arabia Highway: Case Study. *International Journal of Engineering and Technical Research*, 8, 78-84.
- [14] P. Jenkins, M. Elmnifi, A. Younis, & A. Emhamed, (2019). Hybrid Power Generation by Using Solar and Wind Energy: Case Study. *World Journal of Mechanics*, 9(4), 81-93.
- [15] I. Colak, S. Sagiroglu, & M. Yesilbudak, (2012). Data mining and wind power prediction: A literature review. *Renewable Energy*, 46, 241-247.
- [16] T. Sepulveda, & L. Martinez, (2016). Optimization of a hybrid energy system for an isolated community in Brazil. *Int. J. Renew. Energy Res. IJRER*, 6(4), 1476-1481.
- [17] I. Colak, S. Sagiroglu, G. Fulli, M. Yesilbudak, & C. Covrig, (2016). A survey on the critical issues in smart grid technologies. *Renewable and Sustainable Energy Reviews*, 54, 396-405.
- [18] B. Ronad, & S. Jangamshetti, (2015). Optimal cost analysis of wind-solar hybrid system powered AC and DC irrigation pumps using HOMER. In 2015 International Conference on Renewable Energy Research and Applications (ICRERA) (pp. 1038-1042). IEEE.
- [19] I. Colak, F. Kadirgan, and D. Yildirim. (2009). The feasibility report about greenhouse gas emissions reduction by utilization of solar energy to produce electricity.
- [20] I. Colak, & E. Kabalci, (2013). Implementation of energy-efficient inverter for renewable energy sources. *Electric Power Components and Systems*, 41(1), 31-46.
- [21] E. Khan, & A. Martin, (2014). Hybrid renewable energy with membrane distillation polygeneration for rural households in Bangladesh: Pani Para Village case study. In 2014 International Conference on Renewable Energy Research and Application (ICRERA) (pp. 365-368). IEEE.
- [22] V. Charan, (2014, October). Feasibility analysis design of a PV grid connected system for a rural electrification in Ba, Fiji. In 2014 International Conference on Renewable Energy Research and Application (ICRERA) (pp. 61-68). IEEE.
- [23] I. Colak, G. Fulli, S. Bayhan, S. Chondrogiannis, & S. Demirbas, (2015). Critical aspects of wind energy systems in smart grid applications. *Renewable and Sustainable Energy Reviews*, 52, 155-171.
- [24] W. Cao, Y. Du, X. Qi, & L. Ji, (2014, October). Research on operation optimization strategy of grid-connected PV-battery system. In 2014 International Conference on Renewable Energy Research and Application (ICRERA) (pp. 272-279). IEEE.

Appendix A. Sensitivity case & optimization results of scenario A

Export...		Export All...		Sensitivity Cases													Compare Economics	Column Choices...
Left Click on a sensitivity case to see its Optimization Results.																		
Sensitivity	Architecture				Cost				System		SOLAR		WIND					
Power Price (\$/kWh)	SOLAR (kW)	WIND	Grid (kW)	Converter (kW)	Dispatch	COE (\$)	NPC (\$)	Operating cost (\$/yr)	Initial capital (\$)	Ren Frac (%)	Total Fuel (L/yr)	Capital Cost (\$)	Production (kWh/yr)	Capital Cost (\$)	Produ (kW)			
0.0500						999,999	CC	\$0.0500	\$41,825	\$3,235	\$0.00	0						
0.100						999,999	CC	\$0.100	\$83,651	\$6,471	\$0.00	0						
0.150			1			999,999	CC	\$0.0782	\$115,896	\$5,484	\$45,000	72.8	0	45,000	83,48			
0.200			1			999,999	CC	\$0.0918	\$136,081	\$7,046	\$45,000	72.8	0	45,000	83,48			

Export...		Optimization Results													Categorized	Overall		
Left Double Click on a particular system to see its detailed Simulation Results.																		
Sensitivity	Architecture				Cost				System		SOLAR		WIND					
Power Price (\$/kWh)	SOLAR (kW)	WIND	Grid (kW)	Converter (kW)	Dispatch	COE (\$)	NPC (\$)	Operating cost (\$/yr)	Initial capital (\$)	Ren Frac (%)	Total Fuel (L/yr)	Capital Cost (\$)	Production (kWh/yr)	Capital Cost (\$)	Production (kWh/yr)	O&M (\$)		
						999,999	CC	\$0.0500	\$41,825	\$3,235	\$0.00	0						
	5.00			0.156		999,999	CC	\$0.0742	\$62,174	\$3,738	\$13,850	0.103	0	13,750	9,141			
		1				999,999	CC	\$0.0509	\$75,527	\$2,361	\$45,000	72.8	0		45,000	83,484	800	
	5.00	1		0.156		999,999	CC	\$0.0645	\$95,874	\$2,864	\$58,850	72.8	0	13,750	9,141	45,000	83,484	800

Appendix B. Sensitivity case & optimization results of scenario B

Export...		Export All...		Sensitivity Cases													Compare Economics	Column Choices...
Left Click on a sensitivity case to see its Optimization Results.																		
Sensitivity	Architecture				Cost				System		SOLAR		WIND					
Power Price (\$/kWh)	SOLAR (kW)	WIND	Grid (kW)	Converter (kW)	Dispatch	COE (\$)	NPC (\$)	Operating cost (\$/yr)	Initial capital (\$)	Ren Frac (%)	Total Fuel (L/yr)	Capital Cost (\$)	Production (kWh/yr)	Capital Cost (\$)	Produ (kW)			
0.0500						999,999	CC	\$0.0500	\$41,825	\$3,235	\$0.00	0						
0.100						999,999	CC	\$0.100	\$83,651	\$6,471	\$0.00	0						
0.150			1			999,999	CC	\$0.0782	\$115,896	\$5,484	\$45,000	72.8	0	45,000	83,48			
0.200			1			999,999	CC	\$0.0918	\$136,081	\$7,046	\$45,000	72.8	0	45,000	83,48			

Export...		Optimization Results													Categorized	Overall		
Left Double Click on a particular system to see its detailed Simulation Results.																		
Sensitivity	Architecture				Cost				System		SOLAR		WIND					
Power Price (\$/kWh)	SOLAR (kW)	WIND	Grid (kW)	Converter (kW)	Dispatch	COE (\$)	NPC (\$)	Operating cost (\$/yr)	Initial capital (\$)	Ren Frac (%)	Total Fuel (L/yr)	Capital Cost (\$)	Production (kWh/yr)	Capital Cost (\$)	Production (kWh/yr)	O&M (\$)		
						999,999	CC	\$0.100	\$83,651	\$6,471	\$0.00	0						
		1				999,999	CC	\$0.0645	\$95,712	\$3,923	\$45,000	72.8	0		45,000	83,484	800	
	5.00			0.156		999,999	CC	\$0.124	\$103,999	\$6,973	\$13,850	0.103	0	13,750	9,141			
	5.00	1		0.156		999,999	CC	\$0.0781	\$116,058	\$4,425	\$58,850	72.8	0	13,750	9,141	45,000	83,484	800

Appendix C. Sensitivity case & optimization results of scenario C

Export...		Export All...		Sensitivity Cases													Compare Economics	Column Choices...
Left Click on a sensitivity case to see its Optimization Results.																		
Sensitivity	Architecture				Cost				System		SOLAR		WIND					
Power Price (\$/kWh)	SOLAR (kW)	WIND	Grid (kW)	Converter (kW)	Dispatch	COE (\$)	NPC (\$)	Operating cost (\$/yr)	Initial capital (\$)	Ren Frac (%)	Total Fuel (L/yr)	Capital Cost (\$)	Production (kWh/yr)	Capital Cost (\$)	Produ (kW)			
0.0500						999,999	CC	\$0.0500	\$41,825	\$3,235	\$0.00	0						
0.100						999,999	CC	\$0.100	\$83,651	\$6,471	\$0.00	0						
0.150			1			999,999	CC	\$0.0782	\$115,896	\$5,484	\$45,000	72.8	0	45,000	83,48			
0.200			1			999,999	CC	\$0.0918	\$136,081	\$7,046	\$45,000	72.8	0	45,000	83,48			

Export...		Optimization Results													Categorized	Overall		
Left Double Click on a particular system to see its detailed Simulation Results.																		
Sensitivity	Architecture				Cost				System		SOLAR		WIND					
Power Price (\$/kWh)	SOLAR (kW)	WIND	Grid (kW)	Converter (kW)	Dispatch	COE (\$)	NPC (\$)	Operating cost (\$/yr)	Initial capital (\$)	Ren Frac (%)	Total Fuel (L/yr)	Capital Cost (\$)	Production (kWh/yr)	Capital Cost (\$)	Production (kWh/yr)	O&M (\$)		
						999,999	CC	\$0.0782	\$115,896	\$5,484	\$45,000	72.8	0		45,000	83,484	800	
						999,999	CC	\$0.150	\$125,476	\$9,706	\$0.00	0						
	5.00	1		0.156		999,999	CC	\$0.0916	\$136,242	\$5,987	\$58,850	72.8	0	13,750	9,141	45,000	83,484	800
	5.00			0.156		999,999	CC	\$0.174	\$145,824	\$10,209	\$13,850	0.103	0	13,750	9,141			

Appendix D. Sensitivity case & optimization results of scenario D

Export...		Export All...		Sensitivity Cases													Compare Economics	Column Choices...
Left Click on a sensitivity case to see its Optimization Results.																		
Sensitivity	Architecture				Cost				System		SOLAR		WIND					
Power Price (\$/kWh)	SOLAR (kW)	WIND	Grid (kW)	Converter (kW)	Dispatch	COE (\$)	NPC (\$)	Operating cost (\$/yr)	Initial capital (\$)	Ren Frac (%)	Total Fuel (L/yr)	Capital Cost (\$)	Production (kWh/yr)	Capital Cost (\$)	Produ (kW)			
0.0500						999,999	CC	\$0.0500	\$41,825	\$3,235	\$0.00	0						
0.100						999,999	CC	\$0.100	\$83,651	\$6,471	\$0.00	0						
0.150			1			999,999	CC	\$0.0782	\$115,896	\$5,484	\$45,000	72.8	0	45,000	83,48			
0.200			1			999,999	CC	\$0.0918	\$136,081	\$7,046	\$45,000	72.8	0	45,000	83,48			

Export...		Optimization Results													Categorized	Overall		
Left Double Click on a particular system to see its detailed Simulation Results.																		
Sensitivity	Architecture				Cost				System		SOLAR		WIND					
Power Price (\$/kWh)	SOLAR (kW)	WIND	Grid (kW)	Converter (kW)	Dispatch	COE (\$)	NPC (\$)	Operating cost (\$/yr)	Initial capital (\$)	Ren Frac (%)	Total Fuel (L/yr)	Capital Cost (\$)	Production (kWh/yr)	Capital Cost (\$)	Production (kWh/yr)	O&M (\$)		
						999,999	CC	\$0.0918	\$136,081	\$7,046	\$45,000	72.8	0		45,000	83,484	800	
	5.00	1		0.156		999,999	CC	\$0.105	\$156,426	\$7,548	\$58,850	72.8	0	13,750	9,141	45,000	83,484	800
						999,999	CC	\$0.200	\$167,301	\$12,942	\$0.00	0						
	5.00			0.156		999,999	CC	\$0.224	\$187,650	\$13,444	\$13,850	0.103	0	13,750	9,141			