

# Control of PMSG Stand-Alone Wind Turbine System Based on Multi-Objective PSO

Ratna Ika Putri\*<sup>‡</sup>, M. Rifa'i\*, Ika Noer Syamsiana\*, Ferdian Ronilaya\*

\* Department of Electrical Engineering, State Polytechnic of Malang, Malang, East Java, Indonesia

(ratna.ika@polinema.ac.id, muh.rifai@polinema.ac.id, ikanoersyamsiana@polinema.ac.id, ferdian@polinema.ac.id)

<sup>‡</sup> Corresponding Author; Ratna Ika Putri, State Polytechnic of Malang, Jl. Soekarno Hatta No.9, Malang, 65141, Indonesia, Tel: +62 341 404424,

Fax: +62 341 404420, ratna.ika@polinema.ac.id

*Received: 20.04.2020 Accepted: 29.05.2020*

**Abstract-** This paper presents the control strategy for a stand-alone wind turbine system connected to batteries is presented in this paper. The wind turbine system uses permanent magnet synchronous generators (PMSG). The control strategy consists of optimum power extraction based on particle swarm optimization (PSO) and loads voltage control based on multi-objective PSO (MOPSO). The optimum power extraction functions to get optimal power at each wind speed based on voltage and current of converter through the control of the converter duty cycle. While MOPSO will tuning parameter of the proportional integrator (PI) controller which will regulate the bidirectional converter through duty cycle setting so that the dc-link voltage can be held according to the reference value. This control strategy is tested for slowly and rapid wind speed changes. Based on the test results, this control strategy has good performance. The dc-link voltage can be maintained constant at 400V and the power can be extracted optimally even though the wind speed fluctuates rapidly.

**Keywords** Wind Turbine; Multi-objective optimization; PSO; PMSG.

## 1. Introduction

Utilization of electricity using wind energy has increased due to the fossil energy crisis and increased awareness of the use of green energy to reduce environmental pollution. In 2018, the total use of wind energy in the world is around 5% with total production reaching 690.8 GW and is predicted to increase in the next years [1]. Compared to conventional electricity generation, the use of renewable energy is very dependent on environmental conditions and intermittent so that it will produce fluctuating electrical energy. Therefore, the controller is needed to obtain optimal power and in accordance to load requirements. The stand-alone wind energy system is very suitable for remote areas. Stand-alone systems require batteries as storage systems to store excess energy and meet load requirements [2]. If the load requirement is lower than the wind energy produced, the battery will store energy. Conversely, if the load requirements exceed the wind energy produced, the battery supplies the load. For this, battery charge and discharge control are required.

In a stand-alone wind energy system uses batteries. This system consists of a rotor side converter (RSC) and load side

converter (LSC). The RSC functions to regulate the generator speed, therefore, this system operates at optimum power by using a maximum power extraction controller [3]. The dc-link voltage will be maintained constant through battery charge and discharge settings by LSC.. Several studies have been done to investigate the extraction of maximum power in wind turbines. Maximum power extraction was done by setting the tip speed ratio (TSR) at the optimal point. Compared to the TSR method, the optimal torque control (OTC) method is simpler, faster and efficient but the efficiency of the OTC method is lower than the TSR method [4]. The conventional method for maximum power extraction has simple computing time but requires wind speed measurement and turbine characteristics thereby increasing utilization costs. The P&O method was developed to obtain maximum power without measuring wind speed and produce a better response than conventional methods. But the performance of this method is largely determined by the choice of step size which will affect the computational time [5]. Some studies combine intelligent methods to determine the step size of the P&O method [6-8]. Compared to conventional P&O methods, fuzzy logic, PSO, and swarm algorithm produce better performance [9 - 17].

Setting DC link voltage through charging and discharging storage system for stand-alone wind energy systems has been carried out several investigations. The use of batteries and super capacitors can maintain load balance but increase equipment costs due to expensive super capacitor costs [18]. Constant power management by using a battery as a storage system through bidirectional converter settings produces constant power according to load requirements [2][19-21]. The use of batteries to regulate balance power on stand-alone and on-grid systems through bidirectional converters using PI controllers produces good performance[22]. But the determination and tuning of PI parameters are very complicated because it has high linearity and complexity of the system. Incorrect tuning will result in oscillations in dynamic behaviour and system instability [23]. Tuning PI controller parameters using the root locus method on the grid side converter has been applied to wind turbine systems with PMSG[24]. Several optimization methods have also been developed for the use of bacteria foraging (BF) and PSO for optimizing PI controller parameters in wind turbine systems with DFIG that can maintain constant power to the grid [25][23]. However, the use of these methods requires accurate wind and power predictions thereby increasing the memory and equipment requirements for wind measurements [26].

This paper presents the control of a wind turbine system using PMSG and batteries as energy storage. The control system consists of the optimal power extraction and load voltage control. Optimal power extraction uses the PSO method through the measurement of the converter electric parameter to get optimal power. Load voltage control will maintain the dc-link voltage at a certain value even though the wind speed fluctuates. Load voltage control using a battery charger controller via a bidirectional converter using a multi-objective PSO. Multi-objective PSO is used for tuning the proportional integrator (PI) controller parameters that will regulate battery charging and discharging through bidirectional converters so that the load voltage can be kept constant.

**2. Wind Turbine System**

The wind turbine system used in this paper, as shown in Fig 1, consists of a wind turbine, PMSG, uncontrolled rectifier, buck converter, bidirectional converter, battery charger controller, MPPT based on PSO and load. The Wind turbine and PMSG capture wind energy and convert to the electric signal. PMSG produces AC voltage and an uncontrolled three-phase rectifier will convert to DC voltage. Buck converter will convert to a certain DC voltage to get optimum power based on the optimal power extraction algorithm through duty cycle control. The optimal power extraction using PSO will calculate the input power of the buck converter through measurement of voltage and current of the converter at certain wind speeds and produce the duty cycle to drive the switching component on a buck converter based on the PSO algorithm.

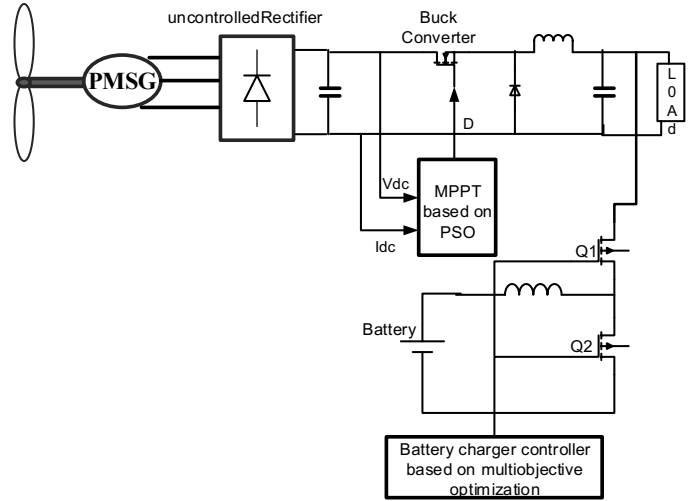

**Fig 1.** Wind Turbine System Block Diagram

Battery charger controller controls charged and discharged the battery to remain load output voltage at a certain value. Battery charger controller adjusts bidirectional converter to charge and discharge battery based on the multi-objective PSO (MOPSO) algorithm. MOPSO will tune the parameter of the proportional integrator (PI) controller based on the reference and dc-link voltage. The proposed system is simulated by Simulink Matlab

**2.1. PMSG Modelling**

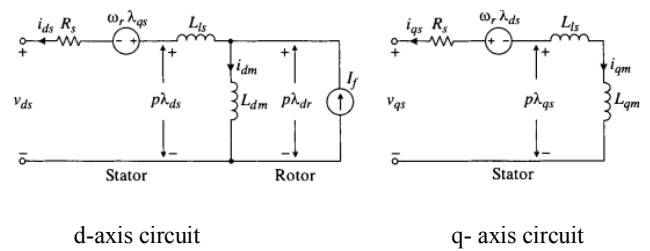

**Fig 2.** PMSG equivalent circuit

The proposed system used PMSG to convert mechanical energy to electrical energy. The use of PMSG in small scale wind turbine system has the advantage because it has simple structure, good efficiency, low maintenance cost and high performance [7][27].

Fig 2 shows PMSG modeling using dq equivalent circuit. Field current in rotor winding is constant current source (I<sub>f</sub>) on d-axis circuit. Voltage equation for PMSG can be expressed by

$$v_{ds} = - i_{ds}.R_s - \omega_r.\lambda_{qs} + p. \lambda_{ds} \tag{1}$$

$$v_{qs} = - i_{qs}.R_s + \omega_r.\lambda_{ds} + p. \lambda_{qs} \tag{2}$$

where *i<sub>d</sub>* is d-axis stator current, *i<sub>q</sub>* is q-axis stator current, *v<sub>d</sub>* is d-axis stator voltage, *v<sub>q</sub>* is q-axis stator voltage, *R<sub>s</sub>* is stator resistance, *L<sub>d</sub>* is d-axis winding inductance (H), *L<sub>q</sub>* is q-axis winding inductance, *p* is pole number, and  $\omega_r$  is PMSG electric rotation speed.  $\lambda_{qs}$  and  $\lambda_{ds}$  is d and q- axis stator flux that can be determined by

$$\lambda_{qs} = - i_{qs}.L_{ls} + L_{qm}.i_{qs}$$

$$= -Lq.iqs \tag{3}$$

$$\lambda ds = -ids.Lls + Ldm.(if - ids)$$

$$= -Ld.ids + \lambda r \tag{4}$$

Where  $\lambda r$  is rotor flux,  $Ld$  and  $Lq$  is dq-axis stator self-inductance, and  $Lqm$  and  $Ldm$  is dq-axis magnet inductance. Electromagnetic torque ( $T_e$ ) produced by PMSG can be calculated by

$$T_e = \frac{3P}{2} (i_{qs} \lambda_r + i_{ds} i_{qs} (L_d + L_q)) \tag{5}$$

The rotor speed of PMSG ( $\omega_r$ ) and electric power generated ( $P$ ) are determined by

$$\omega_r = \frac{P}{J_s} (T_e - T_m) \tag{6}$$

$$P = 1,5(vsd.isd + vsq.isq) \tag{7}$$

In this paper, stator resistance value ( $R_s$ ) is  $0.425\Omega$ , stator inductance ( $L_s$ ) is  $0.0082H$ , pole pairs of PMSG is 10, PMSG flux is  $0.433$  wb and turbine inertia is  $0.01197$  kgm<sup>2</sup>.

2.2. Buck Converter

In this paper, buck converter topology is employed to track optimum power generated through duty cycle control, as shown in Fig 3. Buck converter consists of IGBT as switching component, inductor, capacitor, diode, and load. The duty cycle is adjusted by PSO algorithm, as optimum power extractor, based on input voltage and current of the converter. The duty cycle of pulse width modulation (PWM) signal will drive the switching component that will determine the switch condition.

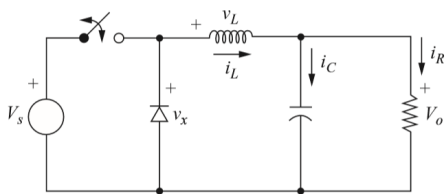

(a) Buck converter circuit

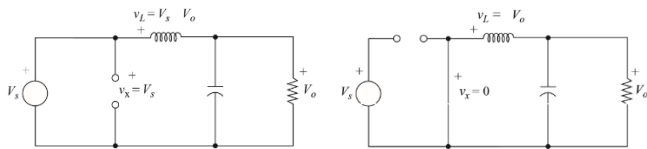

(b) Switch on mode (c) Switch off mode

Fig 3. The Buck Converter

When the switch is closed therefore inductor, capacitor and load is connected by the input voltage and a diode is reversed bias so that input current will flow through inductor and resistor load, as shown in Fig 3b. When a switch is on mode, inductor voltage can be expressed by

$$v_L = V_s - V_o = L \frac{di_L}{dt} \tag{8}$$

$$\frac{di_L}{dt} = \frac{V_s - V_o}{L} \tag{9}$$

Where  $v_L$  is inductor voltage,  $V_s$  is input voltage,  $V_o$  is output voltage,  $L$  is inductance value, and  $i_L$  is inductor current. Changes in the inductor current when the switch is closed can be formulated by

$$\frac{di_L}{dt} = \frac{\Delta i_L}{\Delta t} = \frac{\Delta i_L}{DT} = \frac{V_s - V_o}{L} \tag{10}$$

$$(\Delta i_L)_{closed} = \left(\frac{V_s - V_o}{L}\right) DT \tag{11}$$

Where  $D$  is the duty cycle, and  $T$  is period time. When a switch is an open and off mode, as shown in Fig 3c, all component is not connected by the input voltage and inductor functions as a current source. The diode will forward bias and inductor current flows through it. Inductor voltage when switch off mode can be expressed by

$$v_L = -V_o = L \frac{di_L}{dt} \tag{12}$$

$$\frac{di_L}{dt} = \frac{-V_o}{L} \tag{13}$$

In this condition, the current will decrease linearly and has a negative value. Changes in inductor current on switch off mode can be expressed by

$$\frac{\Delta i_L}{\Delta t} = \frac{\Delta i_L}{(1-D)T} = \frac{-V_o}{L} \tag{14}$$

$$(\Delta i_L)_{open} = \left(\frac{-V_o}{L}\right) (1 - D)T \tag{15}$$

The total value of inductor current in one period ( $T$ ) equals zero and can be expressed by

$$(\Delta i_L)_{closed} + (\Delta i_L)_{open} = 0 \tag{16}$$

$$\left(\frac{V_s - V_o}{L}\right) DT - \left(\frac{V_o}{L}\right) (1 - D)T = 0 \tag{17}$$

So that output voltage is proportional with input voltage and duty cycle that is expressed by

$$V_o = V_s D \tag{18}$$

Based on equation 16-17, inductance value for continuous conduction mode (CCM) can be expressed by

$$\Delta i_L = \left(\frac{V_s - V_o}{L}\right) DT = \left(\frac{V_s - V_o}{L_f}\right) D = \frac{V_o(1-D)}{L_f} \tag{19}$$

$$L = \left(\frac{V_s - V_o}{\Delta i_L f}\right) D = \frac{V_o(1-D)}{\Delta i_L f} \text{ atau } \frac{V_s - V_o}{\Delta i_L f} \tag{20}$$

The capacitance value determines the current ripple value of the capacitor. When the capacitor current is positive, the capacitor will be charging. The capacitance value can be determined by

$$\Delta V_o = \frac{TV_o}{8CL} (1 - D)T = \frac{V_o(1-D)}{8LCf^2} \tag{21}$$

$$\frac{\Delta V_o}{V_o} = \frac{(1-D)}{8LCf^2} \tag{22}$$

$$C = \frac{1-D}{8L(\Delta V_o/V_o)f^2} \tag{23}$$

Where  $f$  is frequency, and  $\Delta V_o$  is the ripple voltage. In this paper, the input voltage of the buck converter has a voltage range between  $37V - 400V$  from an output voltage of a rectifier. The frequency used is  $31.5KHz$  so that inductance

and capacitance values are determined based on equations 20 and 23. The inductance value is 10mH and the capacitance value is 300 μF.

2.3. Bidirectional Converter

The bidirectional converter consists of two IGBTs and an inductor connected to the battery, as shown in Figure 1. The bidirectional converter works through the IGBT switch settings by the controller. IGBT will work alternately depending on the PWM signal sent from the controller. Based on the dc-link voltage and the voltage generated by the wind turbine system, the controller will set IGBT switching to determine battery charging or discharging operations. The bidirectional converter will maintain dc-link voltage according to load requirements.

3. Control System

3.1 Optimal power extraction based on Particle swarm optimization

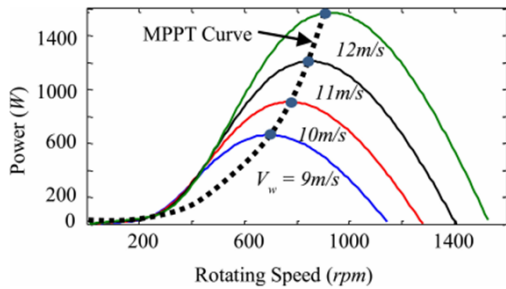

Fig 4. The relationship between output power and rotating speed on the wind turbine system

Fluctuating wind speeds greatly affect the power generated by wind turbines system. To get optimum power on certain wind speeds, the wind turbine system must be operated at optimum power so that a controller is needed to extract optimum power. The relationship between output power generated and rotating speed is shown in Fig 4. Wind speed changed results in optimum output power point shifting. At a certain wind speed, the optimum power can be obtained if generator rotates at a certain speed as well. Therefore, optimum power extraction is done by controlling the generator rotational speed to each change in wind speed so that the power generated will be optimum. The controlling of generator speed can be achieved through controlling of converter duty cycle.

In this paper, PSO algorithm is used as optimum power extraction using the converter output voltage and current. PSO is an optimization method using swarm intelligence that is based on objective functions to be achieved. This algorithm is inspired by the behaviour of a group of birds where social behaviour consists of individual actions and influences from other individuals in a group. Each individual is stated as a particle that has position and speed. A particle shows a solution and has a position. In this paper, the position of the article in the PSO algorithm shows the duty cycle of buck converter. The objective function that will be achieved in this algorithm is the optimization of the converter power which is

determined based on the measurement of the current and the output voltage of the converter. While the particle speed shows the step size of the duty cycle.

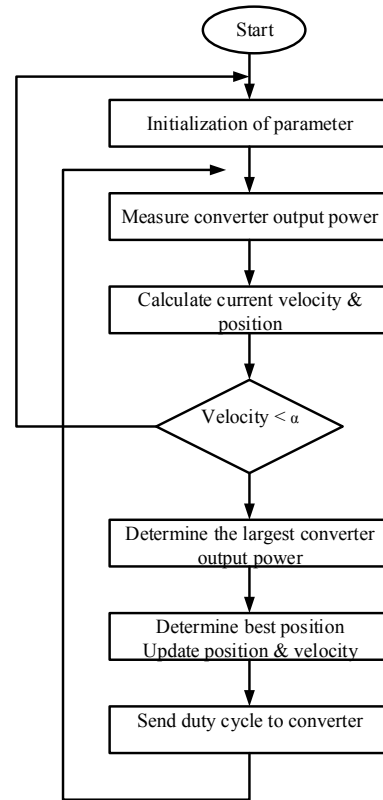

Fig 5. PSO Algorithm Flowchart

The position and speed of particle can be determined by

$$V_i^{k+1} = w V_i^k + C_1 r_1 (d_{pbesti}^k - d_i^k) + C_2 r_2 (d_{gbesti}^k - d_i^k) \quad (24)$$

$$d_i^{k+1} = d_i^k + V_i^{k+1} \quad (25)$$

W is a momentum factor with a value of 0.15. C1 and C2 are acceleration constants of 0.5 and 0.7 respectively, α is a maximum velocity value of 0.03, r1 and r2 are random variables between 0 and 1 generated using a uniform probability.  $d_i^k$  is the current position,  $d_i^{k+1}$  is a modified position,  $d_{pbesti}^k$  is the best position for each particle,  $d_{gbesti}^k$  is the best position in the group,  $V_i^k$  is the current particle velocity and  $V_i^{k+1}$  is the modified velocity of particle. Flowchart of PSO algorithm is shown on Fig 5.

3.2 Battery charger controller based on Multi-objective optimization

The battery charger controller will maintain a dc-link voltage of 400V through a PWM pulse adjustment on the bidirectional converter according to the DC reference voltage. The bidirectional converter will determine the battery charge and discharge based on the PWM pulses sent by the controller. Fig 6 shows a battery charger controller using MOPSO.

MOPSO has two objective functions to optimize the PI controller parameters,  $K_p$  and  $K_i$ . The PI controller will generate a PWM pulse signal for the bidirectional converter based on the difference between the reference dc voltage and the dc-link voltage.

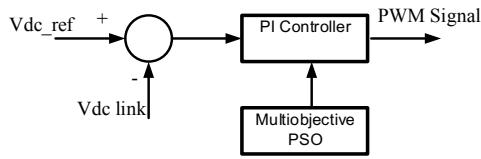

**Fig 6.** Battery Charger Controller using multi objective PSO

MOPSO consists of 10 particles where each particle has two dimensions to determine the parameters  $K_p$  and  $K_i$ . The speed and position of each particle are updated using equations (24) and (25). The objective function of the MOPSO is based on performance criteria for evaluating the PI controller. The performance criteria based on the time domain are better than based on the frequency domain [28]. This paper uses performance criteria consisting of maximum overshoot and steady-state error as an objective function, which can be expressed by

$$F = E_{ss} + \beta + M_p \alpha \tag{26}$$

Where  $E_{ss}$  is a steady-state error,  $M_p$  is maximum overshoot,  $\beta$  and  $\alpha$  are constants. The  $\beta$  and  $\alpha$  values are 0.01 and 0.0001. The PSO fitness function value is determined by the minimum value achieved for each criterion.

#### 4. Simulation Results

The performance of the controller as the optimum power extraction and the battery charger controller is simulated through two conditions namely slowly wind speed changes and rapid wind speed changes. MOPSO tunes the PI controller parameters to maintain a dc-link voltage of 400V against changes in wind speed.

Fig 7 shows the controller performance with the wind speed changes slowly from 8.5 m/s to 11m/s. The wind speed is set at 10.5m/s for 0.6s and it decreases to 8.5m/s. Furthermore, the wind speed changed to 10m/s and 11m/s respectively, as shown in Fig 7(a). Fig 7(b) shows converter output voltage which is proportional to the wind speed. The greater the wind speed, the PMSG output voltage generated will be greater as well as the converter output voltage. The output voltage generated by the Rectifier circuit is proportional to the wind speed. The higher the wind speed will be followed by an increase in the rectifier voltage. At a wind speed of 10.5m/s will produce an output voltage of 500V and at a wind speed of 8.5m/s will produce 400V. The battery charger controller using MOPSO will keep a constant dc voltage of 400V. MOPSO algorithm will determine the proportional integrator controller parameters to regulate the charge and discharge batteries. PI controller parameters tuned through the MOPSO algorithm are  $K_p$  value of 0.4474 and  $K_i$  value of 163.41. At a wind speed of 10.5 m/s, the battery will be charged so that the battery voltage will increase, as shown in Fig 7 (c). Conversely, when the wind speed is 8.5m/s, the battery voltage will drop because the battery is discharged. The dc-link voltage can achieved constant value,

as shown in Fig 7 (d). Fig 7 (e) shows the output power at the load, converter and battery. When the wind speed drops, the power and voltage generated by the converter decrease so that the battery will be regulated in a discharged condition by the battery charger controller to reach the dc-link voltage value equals with the reference value. This is indicated by the battery's output power will increase and the battery voltage will drop when the battery is discharged. Although the wind speed changes, the MOPSO algorithm can maintain a constant DC link voltage of 400V.

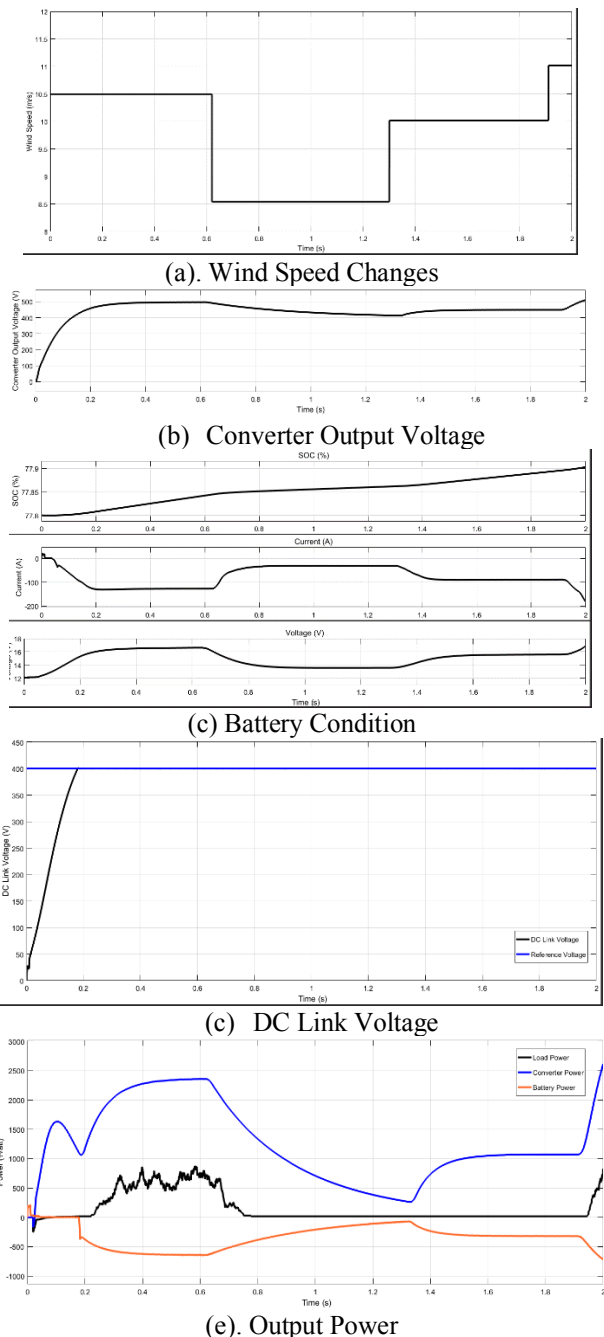

**Fig 7.** Simulation Result With Wind Speed Changes Slowly

MOPSO controller performance was also tested in conditions of rapid wind speed changes and simulation results are shown in Fig8. The wind speed changes between 7m/s until 11m/s rapidly and fluctuates as shown in figure 8a. The



converter output voltage is proportional to the wind speed and can follow wind speed changes rapidly, as shown in Fig 8 (b). Although the wind speed changes rapidly, the link dc voltage can be held constant according to the reference, as shown in Fig 8 (d). The MOPSO algorithm tunes the PI controller parameters and produces  $K_p$  of 0.4297 and  $K_i$  of 107.14. The bidirectional converter setting can adjust the conditions of the battery so that the dc-link voltage will be kept constant. Fig 8(c) describes battery condition. When the wind speed is low, the battery will be discharging to supply voltage to the load so that the battery voltage decreases. Fig 8 (e) shows the power of a battery, converter and load against wind changes.

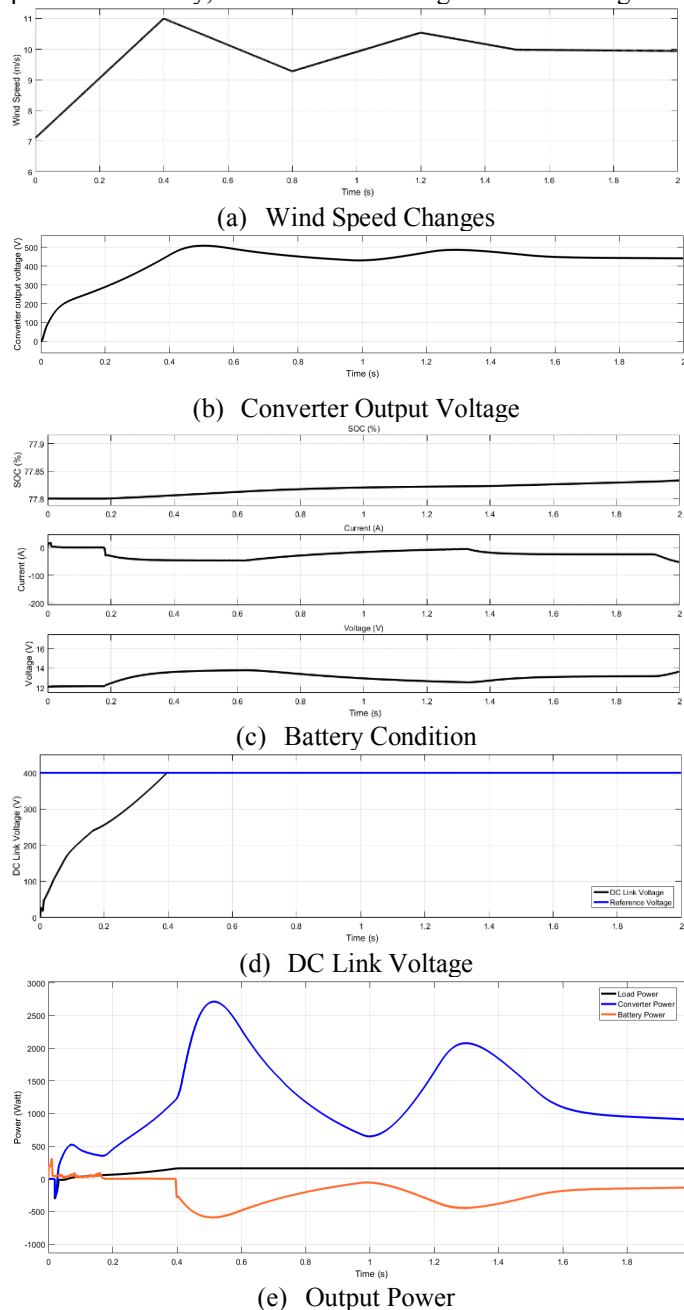

Fig 8. Simulation Result with Rapid Wind Speed Changes

### 5. Conclusion

A wind turbine system with PMSG will produce fluctuating output power and voltage because it depends on intermittent wind speeds. This requires a controller to get optimum power and a constant dc-link voltage according to the reference even though the wind speed is changing. This paper presents PSO-based maximum power extractor and MOPSO-based battery charger controllers on a wind turbine system with PMSG in an off-grid application. The controller performance is simulated on slowly wind speed changes and rapid wind speed changes. Based on test results, PSO can extract optimum power following changes in wind speed. While the MOPSO algorithm can tune the parameter of PI controller so that the dc-link voltage is maintained at 400V even though the wind speed changes rapidly and fluctuations. Future work will develop this algorithm to implement on the prototype of small scale PMSG wind turbine system. Additional performance of wind turbine system connected to grid will be solve in the future.

### Acknowledgments

The authors would like to thank the Ministry of education and culture, Indonesia for the the full financial support.

### Reference

- [1] B.T Kotb, S.M Arafa, S. R Haitham, B Mohamed, E.E.El-Kholy. "Wind Energy Conversion System Topologies and Converters:Comparative Review", Energy Procedia, Vol.162, pp. 38-47, 2019
- [2] S Shruti, P Gatadhar, PY Satya. "Dynamic Modelling and Control of PMSG Based Stand-alone Wind Energy Conversion System", Recent Advances on Engineering, Technology and Computational Sciences, 2018
- [3] R Tiwari, NR Babu, "Recent developments of control strategies for wind energy conversion system," Renewable Sustainable Energy Review, vol. 66, pp. 268–285, December. 2016.
- [4] M. Eltamaly and H. M. Farh, "Maximum power extraction from wind energy system based on fuzzy logic control," Electrical Power System Research, vol. 97, pp. 144–150, April. 2013
- [5] Z. M. Dalala, Z. U. Zahid, W. Yu, Y. Cho, and J.-S. Lai, "Design and Analysis of an MPPT Technique for Small-Scale Wind Energy Conversion Systems," IEEE Transaction Energy Conversion, vol. 28, no. 3, pp. 756–767, September. 2013.
- [6] K. L. Lian, J. H. Jhang, and I. S. Tian, "A Maximum Power Point Tracking Method Based on Perturb-and-Observe Combined With Particle Swarm Optimization," IEEE Journal of Photovoltaics, vol. 4, no. 2, pp. 626–633, March. 2014.
- [7] RI Putri, IN Syamsiana, M. Rifa'i, "Power Extraction Optimization Of Pmsg Wind Turbine System Based On Simple Modified Perturb & Observe", ICIC Express Letters Part B: Applications, Vol. 11, No. 1, 2020.
- [8] AR. Youssef, A.I.M Ali, M.S.R Saeed, E.E.M Mohamed, "Advanced Multi Sector P&O Maximum Power Point Tracking Technique For Wind Energy

- Conversion System”, *Electrical Power and Energy System*, 107, PP.89-97, 2019.
- [9] S. Kahla, Y. Soufi, M. Sedraoui, M. Bechouat, “On-Off control based particle swarm optimization for maximum power point tracking of wind turbine equipped by DFIG connected to the grid with energy storage,” *International Journal of Hydrogen Energy*, vol. 40, no. 39, pp. 13749–13758, October. 2015.
- [10] T. Chakrabarti, U. Sharma, S. Manna, T. Chakrabarti, and S. K. Sarkar, “Design of intelligent Maximum Power Point Tracking (MPPT) technique based on swarm intelligence based algorithms,” in 2015 International Conference on Power and Advanced Control Engineering, pp. 173–177, 2015.
- [11] C. Bhattacharjee and B. K. Roy, “Advanced fuzzy power extraction control of wind energy conversion system for power quality improvement in a grid tied hybrid generation system,” *IET Generation, Transmission & Distribution*, Vol. 10, no. 5, pp. 1179–1189, 2016.
- [12] J. Lee and Y.-S. Kim, “Sensorless fuzzy-logic-based maximum power point tracking control for a small-scale wind power generation systems with a switched-mode rectifier,” *IET Renewable Power Generation*, vol. 10, no. 2, pp. 194–202, 2016.
- [13] A.A Salem, N.A Nour Aldin, A.M Azmy, W.S.E Abdelatif, “A Fuzzy Logic-Based MPPT Technique for PMSG Wind Generation System”, *International Journal of Renewable Energy Research*, Vol 9, No.4, December 2019
- [14] M. Allouche, S. Abderrahim, H. Ben Zina, M. Chaabane, “A Novel Fuzzy Control Strategy For Maximum Power Point Tracking of Wind Energy Conversion System”, *International Journal of Smart Grid*, Vol. 3, No. 3, pp. 120-127, September 2019
- [15] R.I. Putri, I. Mahmudi, M. Pujiantara, A. Priyadi, M.H. Purnomo, “Modified Firefly Algorithm for Improved Maximum Power Extraction on Wind Energy Conversion System”, *International Journal of Renewable Energy Research*, Vol 8, No.3, September 2018.
- [16] Y. Mokhtari, D. Rekioua, “High Performance of Maximum Power Point Tracking Using Ant Colony Algorithm in Wind Turbine”, *Renewable Energy*, Vol. 126, pp. 1055 – 1063, 2018.
- [17] R. Tiwari, K. Kumar, R. Babu, K.R. Prabhu, “Coordinated MPPT and DPC Strategies For PMSG Based Grid Connected Wind Energy Conversion System”, *Energy Procedia*, Vol. 145, pp. 339 – 344, 2018
- [18] N. Mendis, K. M. Muttaqi, and S. Perera, “Management of Battery-Supercapacitor Hybrid Energy Storage and Synchronous Condenser for Isolated Operation of PMSG Based Variable-Speed Wind Turbine Generating Systems,” *IEEE Transactions on Smart Grid*, vol. 5, no. 2, pp. 944–953, March 2014.
- [19] U.K. Shafquat, A.I. Maswood, H.D. Tafti, “Control of Bidirectional DC/DC Converter for Back to Back NPC-based Wind Turbine System Under Grid Faults”, 4th International Conference on the Development in the in Renewable Energy Technology, 2016.
- [20] B. Housseini, A.F. Okou, R. Beguenane, “Robust Nonlinear Controller Design For On-grid/Off-grid Wind Energy Battery Storage System”, *IEEE Transactions on Smart Grid*, Vol. 9, pp. 5588 - 5598, 2018.
- [21] Z. Malekjamshidi, M. Jafari, J. Zhu, D. Xizo, “Bidirectional Power Flow Control With Stability Analysis of The Matrix Converter For Microgrid Applications”, *Electrical Power and Energy Systems*, Vol. 110, pp. 725 – 736, 2019.
- [22] M. M. Hussein, T. Senjyu, M. Orabi, M. A. A. Wahab, and M. M. Hamada, “Control of a grid connected variable speed wind energy conversion system,” in 2012 International Conference on Renewable Energy Research and Applications, pp. 1–5, 2012.
- [23] M.E.B Aguilar, D.V Coury, R Reginatto, “Multi-objective PSO Applied to PI Control of DFIG Wind Turbine Under Electrical Fault Conditions”, *Electric Power System Research*, Vol 180, 2020.
- [24] M. Hussein, T. Senjyu, M. Orabi, M. Wahab, and M. Hamada, “Control of a Stand-Alone Variable Speed Wind Energy Supply System,” *Applied Science.*, vol. 3, no. 2, pp. 437–456, April. 2013
- [25] Y. Mishra, S. Mishra, and F. Li, “Coordinated Tuning of DFIG-Based Wind Turbines and Batteries Using Bacteria Foraging Technique for Maintaining Constant Grid Power Output,” *IEEE Systems Journal.*, vol. 6, no. 1, pp. 16–26, March. 2012.
- [26] M. Pujiantara, R.I Putri, A. Ario, I. Setiawan, S.Sidarjanto, A. Priyadi, M. H Purnomo, "Output Power Smoothing of Doubly Fed Induction Generator Wind Turbine Using Very Short Term Wind Speed Prediction Based on Lavenberg Marquardt Neural Network", *International Review On Modeling and Simulations*, Vol. 8, No. 8, pp: 558-565, October 2015.
- [27] M. Belkaid, I. Colak, K. Kayisli, R. Bayindir, “Modeling of a Permanent Magnet Synchronous Generator in a power Eind geration System with an Electrochemical Energy Storage”, *International Journal of Smart Grid*, Vol. 2, No. 4, pp. 197-202, December 2018
- [28] R.I. Putri, A. Priyadi, M. Pujiantara, M.H Purnomo., “Tuning PI Controller Based on Multiobjective Optimization Approaches for Speed Control of PMSG Wind Turbine,” *International Review on Automatic Control*, vol. 8, no. 4, pp. 315–321, July. 2015.